

AGRICULTURAL MACHINERY

sitrex®
Spa

ASSEMBLY, USE AND MAINTENANCE

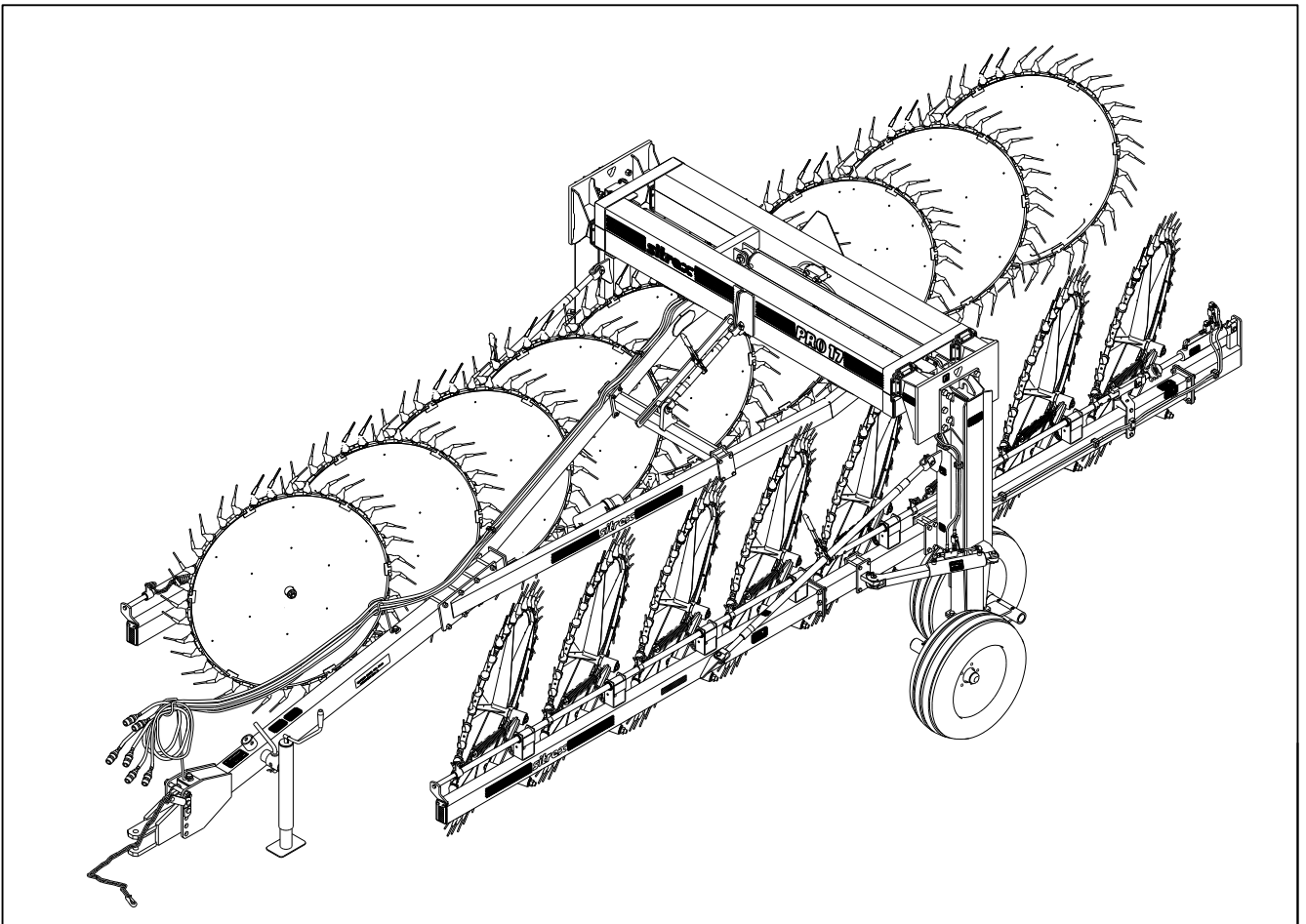

PRO SERIES 17 WHEELS

11-2015 (six hoses)

WARRANTY

On delivery, check that the machine has not been damaged during transport and that all the attachments are present. Claims must be made in writing to the agent within 8 days of receipt.

The manufacturer warrants new machinery at the time of delivery to the original purchaser to be free from defects in material and workmanship if properly set up and operated in accordance with this Operator's Manual.

The manufacturer undertakes to repair or replace free of charge any defective part which should be returned by the purchaser (freight prepaid) and found to be defective by inspection authorized by the manufacturer during the warranty period.

This warranty will be valid for 12 (twelve) months from the delivery of goods to the original purchaser .

In case the customer is not in a position to return the defective part to the manufacturer , the manufacturer cannot be held responsible for any cost due for repair or replacement of any part of the machine , he will only supply the part(s) required for the repair and/or replacement.

The warranty is null and void when it is evident that the machine has been improperly used or however repaired without authorization.

The manufacturer undertakes no responsibility for any obligation or agreement reached by any employers, agents or dealers, which are not in compliance with the above warranty . The manufacturer cannot be held responsible for the consequent damages. This warranty substitutes any other warranty , express or implied , and any other manufacturer's obligation.

NOTE: ALL WARRANTY WORK OR REPAIRS MUST BE APPROVED BY THE MANUFACTURER BEFORE WORK BEGIN. ANY WORK OR REPAIRS MADE BEFORE APPROVAL MAY NOT BE COVERED UNDER WARRANTY. PLEASE NOTIFY YOUR SALES & SERVICE DEPARTMENT OF THIS POLICY.

CHAPTER

- 1) GUIDE TO THE SIGNS
- 2) **General summary of safety and accident-prevention instructions**
- 3) **PRODUCT IDENTIFICATION**
- 4) **DELIVERY AND ASSEMBLY**
- 5) **ADJUSTMENT, PREPARATION AND USE**
- 6) **MAINTENANCE DIRECTIONS**

1) GUIDE TO THE SIGNS AND SYMBOLS USED ON THE MACHINE

IMPORTANT

These signs and symbols give information to the operator on how to make the best use of the machine so as to prolong life, avoid damage, optimise work and, above all, to avoid injury to the operator and anyone within range of the machine. Note well: most of the symbols that you will find below are located on the machine, but some are only in this manual and indicate how to act or what must be done during assembly, when maintenance or repairs are being done, etc..

WARNING SIGNS

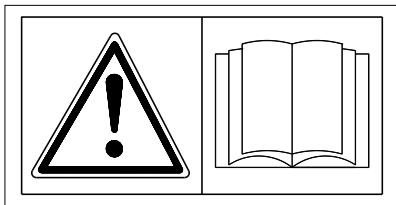

1) Before beginning operations, read the instruction manual carefully.

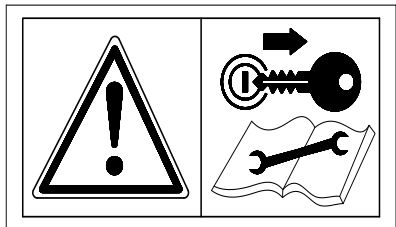

2) Before doing any maintenance or repair work, stop the machine at a suitable spot. Turn off the tractor motor, apply the brake, remove the key from the ignition and consult this manual.

DANGER SIGNS

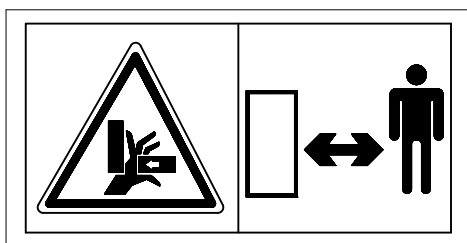

3) Warns against potential serious danger of hands being crushed.
Keep away.

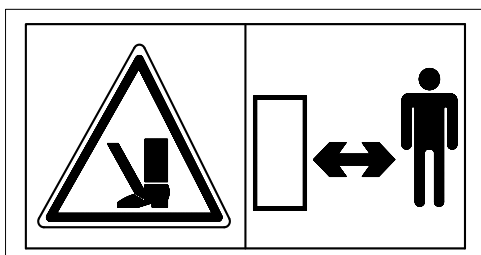

4) Warns against potential serious danger of injury to the feet.
Keep away.



5) Use paper or cardboard to check for and/or clean any leaks from cylinders and oleo dynamic components in general. Never touch with bare hands, as it is harmful to the skin.



6) Warns against the potential and serious dangers to the driver and/or other persons who are near or on the machine or tractor when the tractor is used improperly and/or incautiously.

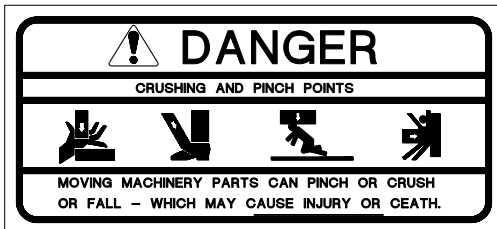

7) Summarizes all the potential and serious dangers that one risks when working improperly on the machine during assembly, use, maintenance or repair.

SYMBOLS FOR INDICATIONS AND/OR RULES

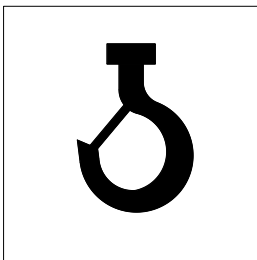

8) Indicates where a hook should be attached to the machine or to part of it if it needs to be lifted.



9) Indicates the components to be assembled on the right or left side of the machine. The R and L sides of the machine are usually determined by standing behind the machine and looking forward.

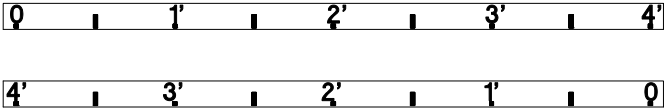

10) Indicates in feet (0'-4') the width of the machine on the right and left side.

**MAXIMUM SPEED FOR ROAD
TRANSPORT MPH 19**

11) Indicates the maximum speed during transport (19 MPH - 30 Km/h)

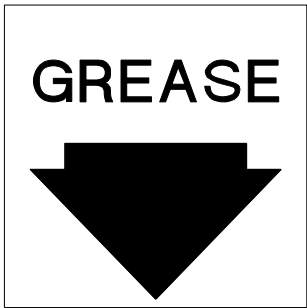

12) Indicates a greasing point.

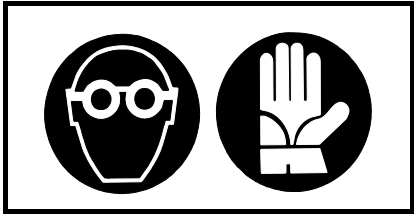

13) Recommends working with suitable clothing and/or protection during assembly, use, maintenance and repair.

Note: For the location of signs and symbols on the machine, see drawing on pg. 8-9.

2) GENERAL SUMMARY OF SAFETY AND ACCIDENT PREVENTION INSTRUCTIONS

Read all the directions carefully before using the machine. When in doubt, seek advice from the manufacturers. The manufacturing company declines all responsibility for non-compliance with the following safety and accident-prevention instructions.

- 1-** Pay attention to the danger signs and symbols in this manual and on the machine.
- 2-** Do not touch moving parts.
- 3-** All work on the machine (including adjustments) must always be carried out with the tractor immobilized and the engine switched off.
- 4-** It is strictly prohibited to carry persons or objects on the machine and/or on the tractor.
- 5-** Driving the tractor with the machine connected is absolutely forbidden to persons lacking suitable experience, or who are in poor health, or who do not have a suitable driving license.
- 6-** All accident-prevention measures recommended in this manual should be scrupulously observed.
- 7-** When a machine is attached to the tractor, always evaluate the suitability of the tractor for the purpose, in order to work safely. Keep in mind that when a machine is attached to the tractor – even if it is a towed type – it alters the tractor’s stability, and therefore all the necessary precautions must be taken (ballast, tire pressure, etc.).
- 8-** Before operating the tractor and machine, check that all transport and operational safety devices are complete and working.
- 9-** When driving on public roads, you should comply with the Highway Code regulations for the country concerned.
- 10-** Before starting work, familiarize yourself with the control devices and how they work.
- 11-** Wear suitable clothes. Do not wear clothing which is loose or which could become entangled in rotating or moving parts.
- 12-** Never leave the driving seat when the tractor is running.
- 13-** It is extremely important to appreciate that road holding, steering and braking may be significantly affected with the machine attached.
- 14-** Before connecting unit, stop the engine, apply the parking brake and remove the ignition key from the instrument panel.
- 15-** Spare parts must meet the requirements as defined by the manufacturer. Use only original spare parts.
- 16-** Safety decals must always be clearly visible. They must be kept clean and replaced if they become too illegible (they can be ordered from the agent if necessary).

3) PRODUCT IDENTIFICATION

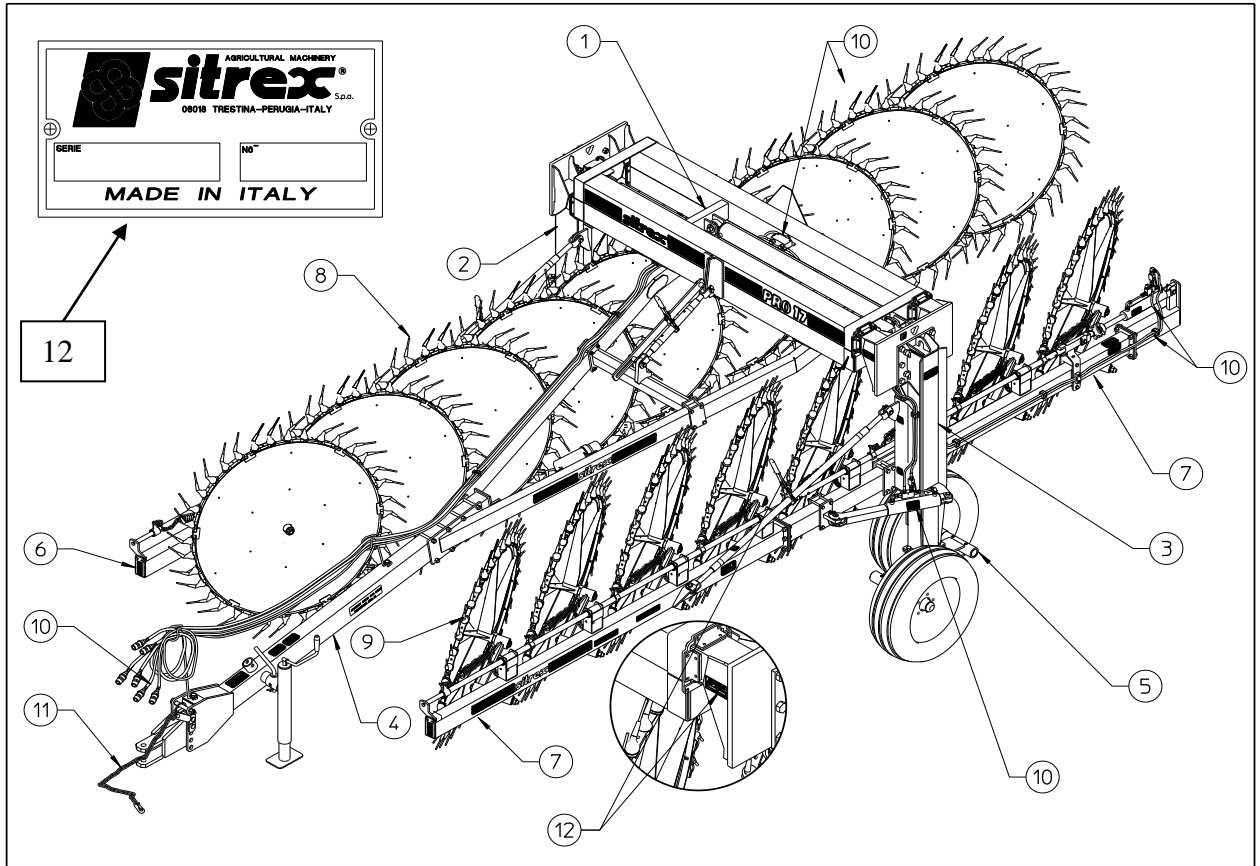

MAIN PARTS

1	CROSSPIECES ASSEMBLY	7	LEFT SIDE SECTIONS
2	RIGHT SUPPORT	8	RIGHT RAKE WHEELS & ACCESSORIES
3	LEFT SUPPORT	9	RIGHT RAKE WHEELS & ACCESSORIES
4	DRAWBAR	10	OLEODYNAMIC COMPONENTS
5	TANDEM ASSEMBLY	11	SAFETY CHAINE
6	RIGHT SIDE SECTIONS	12	IDENTIFICATION PLATE

TECHNICAL DATA

SPECIFICATIONS	PRO/17
Number of wheels	17
Wheels diameter	60"
Teeth for wheel	36
Teeth	Rubber mounted in a set of 2
Trasport width	12' 3"
Trasport leghth	28' 3"
Maximum raking width	29'
Maximum finished windrow width	72"
Rake wheel hubs	Tapered bearing
Tires	10.0/75-15,3
Minimum power required	80 HP - 60 KW
Weight	3000 kg - 6610 lbs

All data are indicative. Sitrex reserves the right to change them without advance notice.

LOCATION OF LABELS AND DEVICES FOR SAFETY, FOR CONTROLS AND FOR IDENTIFICATION OF THE MACHINE AND THE MANUFACTURER.

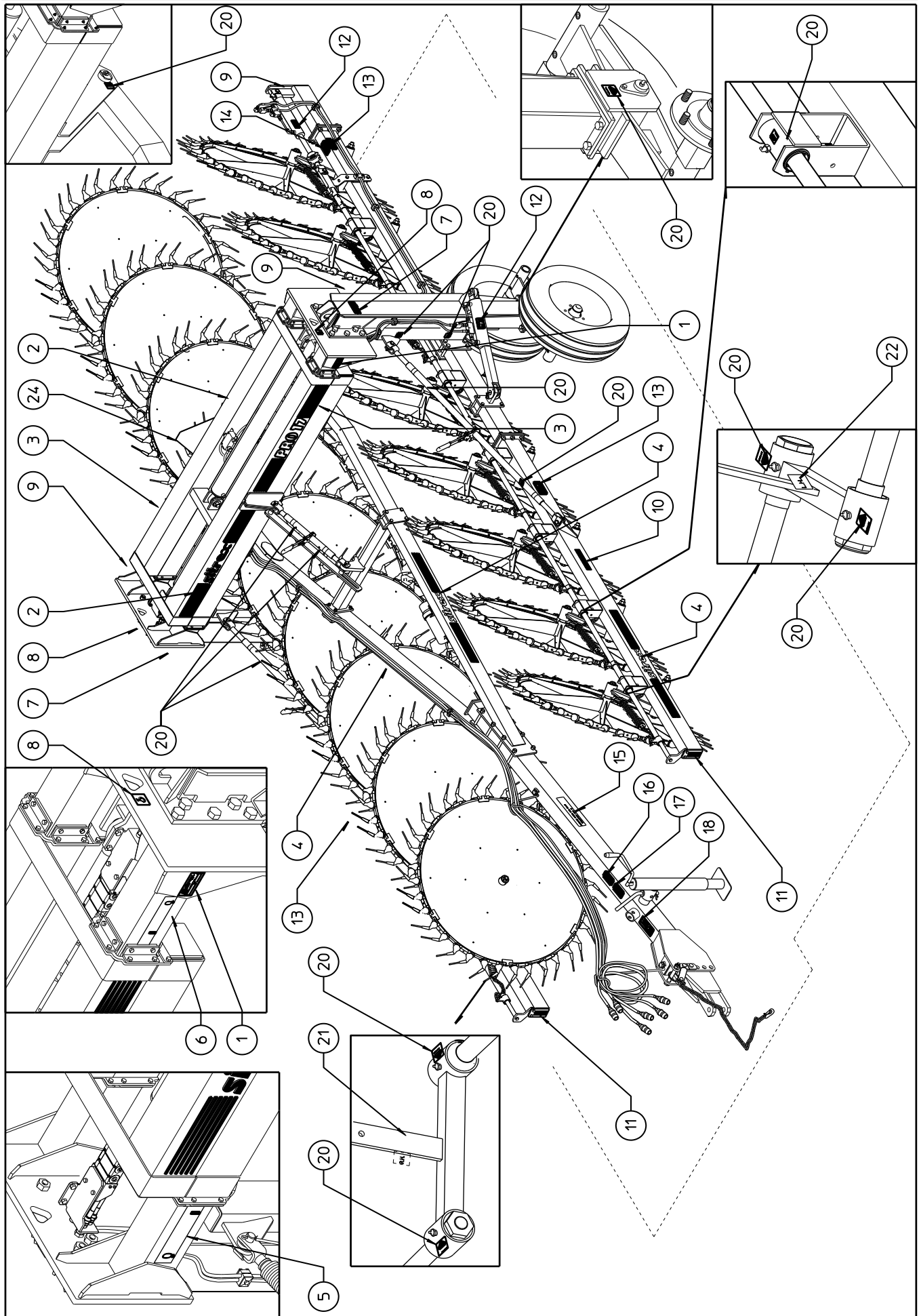

LOCATION OF LABELS AND DEVICES FOR SAFETY, FOR CONTROLS AND FOR IDENTIFICATION OF THE MACHINE AND THE MANUFACTURER

1	IDENTIFICATION PLATE	1	*
2	LARGE SITREX LOGO	2	*
3	"PRO 17" STICKER	2	*
4	SMALL SITREX LOGO	4	*
5	RH EXTENSION MEASUREMENT STICKER	1	See pg.5 (point 10)
6	LH EXTENSION MEASUREMENT STICKER	1	See pg.5 (point 10)
7	"DANGER" STICKER	2	See pg.4 (point 7)
8	"LIFTING HOOK" STICKER	2	See pg.4 (point 8)
9	RED REFLEX REFLECTOR	4	*
10	YELLOW REFLEX REFLECTOR	2	*
11	SMALL YELLOW REFLEX REFLECTOR	2	*
12	"WARNING....." STICKER	9	See pg.4 (point 5)
13	"DANGER FOR FEET" STICKER	10	See pg.3 (point 4)
14	"DANGER OF CRUSHING HANDS" STICKER	11	See pg.3 (point 3)
15	"MAXIMUM SPEED" STICKER	2	See pg.5 (point 11)
16	"OPERATOR'S MANUAL" STICKER	1	See pg.3 (point 1)
17	"OPERATOR'S MANUAL" STICKER	1	See pg.3 (point 2)
18	"WARNING....." STICKER	1	See pg.4 (point 6)
19	DELETED		
20	"GREASE POINT" STICKER	65	See pg.5 (point 12)
21	"R.H." SIDE STICKER	9	See pg.4 (point 9)
22	"L.H." SIDE STICKER	8	See pg.4 (point 9)
23	DELETED		
24	REFLEX REFLECTOR TRIANGLE	1	*

4) DELIVERY AND ASSEMBLY

CHECKING THE MACHINE ON DELIVERY

All parts are carefully checked before dispatch or delivery.

On receiving the machine, ensure that it not been damaged during transport. If damage has occurred, contact the dealer concerned.

Note well: the packing consists of wood, plastic film, cardboard and steel supports, and must be disposed of according to the laws in force in your area.

Handle the crates and pallets received using power lifts suitable for lifting the weights given. Crate B contains the crosspieces assembly 1 and is the heaviest. To correctly handle the pallet with the rake wheels the forks of the forklift 2 must go all the way through and out the opposite side of the pallet.

In order to unpack the rake wheels, screws 3 must be removed.

Each machine arrives packed in two crates and one pallet

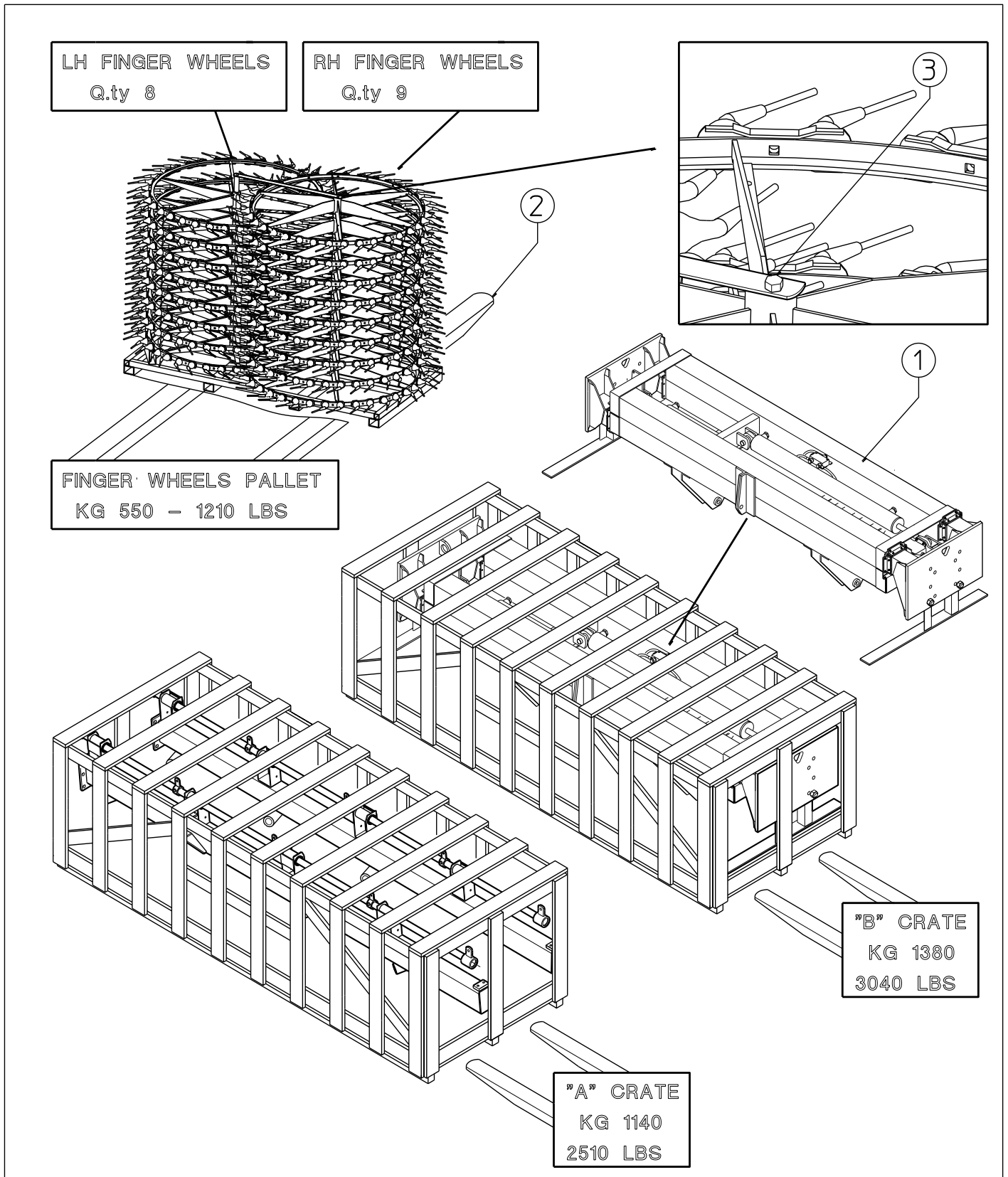

Assembly instructions

Examples of general measurements for identifying the assembly accessories based on type.

To make it easier to identify the assembly accessories (bolts, nuts, washers, pins, etc.) according to the general dimensions and the type, we provide a diagram that shows you the accessory parts to which the measurements refer in the various steps of the assembly.

The illustrations are schematic and do not faithfully represent the accessories, but they are nonetheless an aid in identifying them correctly.

Note well: the accurate measurements are those given in mm; those given in inches are rounded off and therefore as regards the thread sizes the figure in inches is given only as an aid, as they do not accurately describe the thread.

You can see the following examples:

Box “A”: shows the springs that are identified with the diameter of the wire, the outside diameter and the length, thus in this case $\emptyset 3\text{-}\emptyset 18 \times 110$ ($\emptyset 0.12\text{''-}\emptyset 0.71\text{''} \times 4.33\text{''}$)

Box “B”: shows the handles, spring pins, split pins, etc. that are identified with the diameter of the shaft and the length, thus in this case $\emptyset 8 \times 50$ ($\emptyset 0.12\text{''} \times 1.97\text{''}$)

Box “C”: shows the shims, bushings, spacers and washers in general that are identified with the inside diameter, outside diameter and length and/or thickness (for washers), thus in this case $\emptyset 18\text{-}\emptyset 35 \times 30$ ($\emptyset 0.71\text{''-}\emptyset 1.38\text{''} \times 1.18\text{''}$) or for the washers $\emptyset 18\text{-}\emptyset 35 \times 3$ ($\emptyset 0.71\text{''-}\emptyset 1.38\text{''} \times 0.12\text{''}$).

Box “D”: shows the pins, bolts, etc. that are identified with the outside diameter (thread diameter for bolts) and length, thus in this case $\emptyset 20 \times 70$ ($\emptyset 0.78\text{''} \times 2.76\text{''}$) or for the bolts M20 x 70 ($0.78\text{''} \times 2.76\text{''}$).

Box “E”: shows the nuts and grease nipples that are identified with the thread diameter, thus in this case M10 (0.39'').

Box “F”: shows the R-clips that are identified with the wire diameter, thus in this case $\emptyset 3$ ($\emptyset 0.12\text{''}$).

Assembly instructions

Examples of general measurements for identifying the assembly accessories based on type.

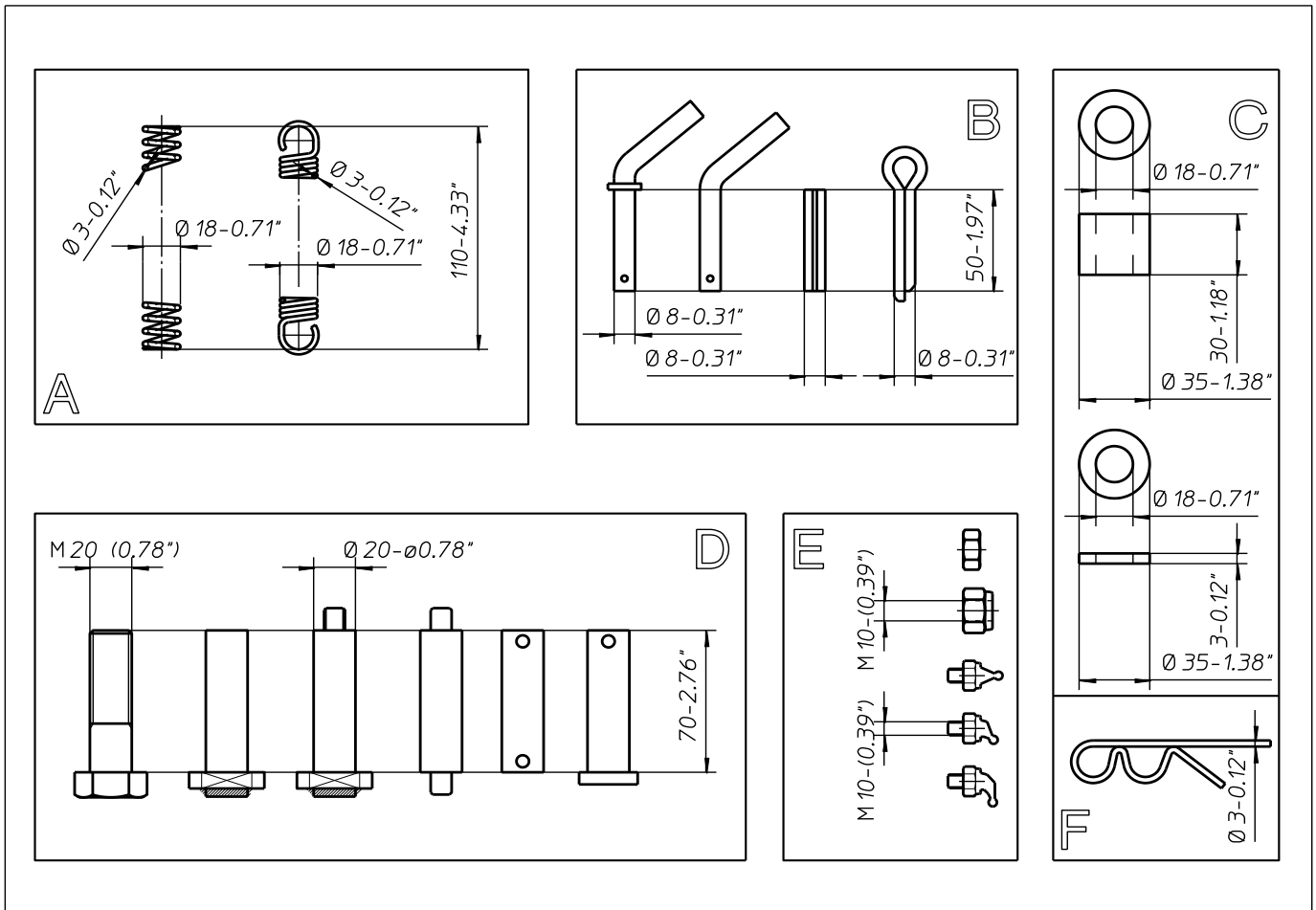

When tightening the bolts refer to the tightening torque table (the class of the material is generally stamped on the head of the bolts).

MINIMUM HARDWARE TIGHTENING TORQUES

IN NEWTON-METERS (FOOT POUNDS) FOR NORMAL ASSEMBLY APPLICATIONS

METRIC NON-FLANGED HARDWARE AND LOCKNUTS

NOMINAL SIZE	CLASS 5.8		CLASS 8.8		CLASS 10.9		LOCKNUT CL.8 W/CL.8 BOLT
	UNPLATED	PLATED W/ZnCr	UNPLATED	PLATED W/ZnCr	UNPLATED	PLATED W/ZnCr	
M4	1.7 (15)*	2.2 (19)*	2.6 (23)*	3.4 (30)*	3.7 (33)*	4.8 (42)*	2.3 (20)*
M6	5.8 (51)*	7.6 (67)*	8.9 (79)*	12 (102)*	13 (115)*	17 (150)*	7.8 (69)*
M8	14 (124)*	18 (159)*	22 (195)*	28 (248)*	31 (274)*	40 (354)*	19 (169)*
M10	28 (21)	36 (27)	43 (32)	56 (41)	61 (45)	79 (58)	38 (28)
M12	49 (36)	63 (46)	75 (55)	97 (72)	107 (79)	138 (102)	66 (49)
M16	121 (89)	158 (117)	186 (137)	240 (177)	266 (196)	344 (254)	164 (121)
M20	237 (175)	307 (226)	375 (277)	485 (358)	519 (383)	671 (495)	330 (243)
M24	411 (303)	531 (392)	648 (478)	839 (619)	897 (662)	1160 (855)	572 (422)

NOTE: Torque values shown with * are inch pounds.

ASSEMBLY SEQUENCE

RH SIDE

C

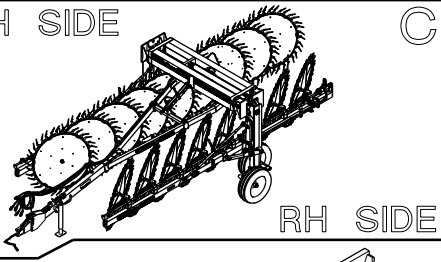

KG 800
1760 LBS

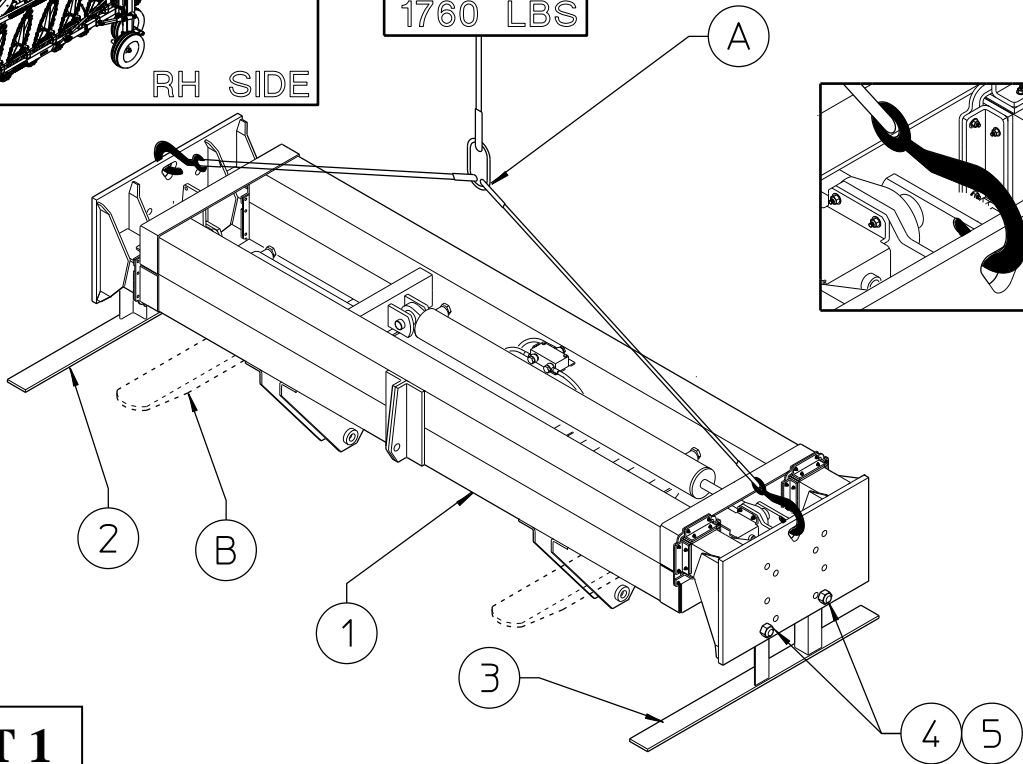
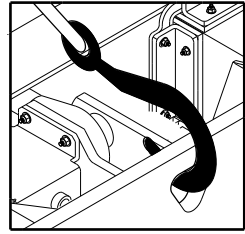

POINT 1

KG 110
2440 LBS

KG 155
340 LBS

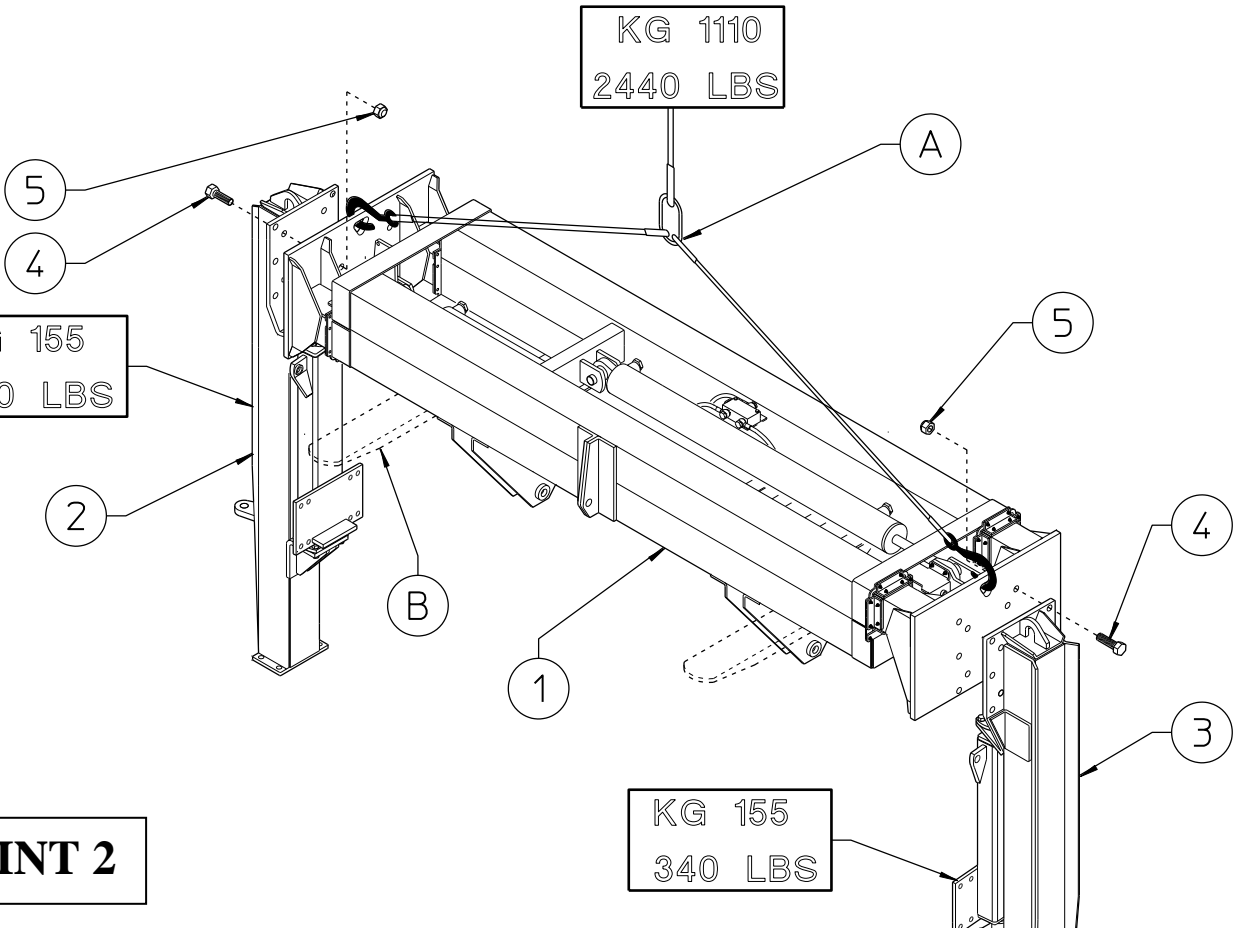

POINT 2

Assembly Sequence

Note: In the description of the assembly sequence the terms “right” and “left” will be used in reference to the sides of the machine. “Right” and “left” are conventionally assigned looking at the machine from the rear (see box “C”).

As already mentioned in the recommendations in the assembly instructions chapter, much care and caution as well as the proper tools and a suitable area must be used during these operations. Keep in mind that up until stage 3 the components to be assembled are heavy and unstable and therefore potentially dangerous for the persons in charge of handling. Note: the weights given for the various components are to be considered as having a tolerance of +/- 5%, as they depend on the tolerances of the original materials. Remember that the weight refers to the quantity of one piece. The weight given for the lifting cable includes the parts assembled in that stage. Only weights of a significant amount are shown (over 15 kg-35lbs).

Point 1 (DANGER)

Remove the rear crosspieces assembly 1 from the packing using a type A or B lift suitable for the weight to be lifted (800 kg – 1760 lbs). Keep in mind that the parts to be attached during the assembly stage done with the aid of the lift will increase the weight to be supported from the present 800 kg – 1760 lbs to the 1310 kg – 2885 lbs of assembly stage 3, after which the lift will be needed to keep the assembled parts in balance. Therefore it is recommended that a lift be used that is suitable for the weight that will be reached in stage 3.

Remove the packing supports 2-3 by unscrewing nuts 4 and bolts 5. Supports 2-3 and nuts 4 and bolts 5 are not to be used for assembly.

Point 2 (DANGER)

Note: the hoses have already been connected to assembly 1, therefore be careful not to damage these parts during handling and assembly.

Attach supports 2-3 (RH and LH) to the rear crosspieces assembly 1 using bolts 4 and nuts 5.

In this step, you will use:

Item 4: 20 bolts M20x60 (0.78” x 2.36”)

Item 5: 20 nuts M20 (0.78”)

POINT 3

KG 1310
2885 LBS

KG 15
35 LBS

KG 28
62 LBS

KG 40
90 LBS

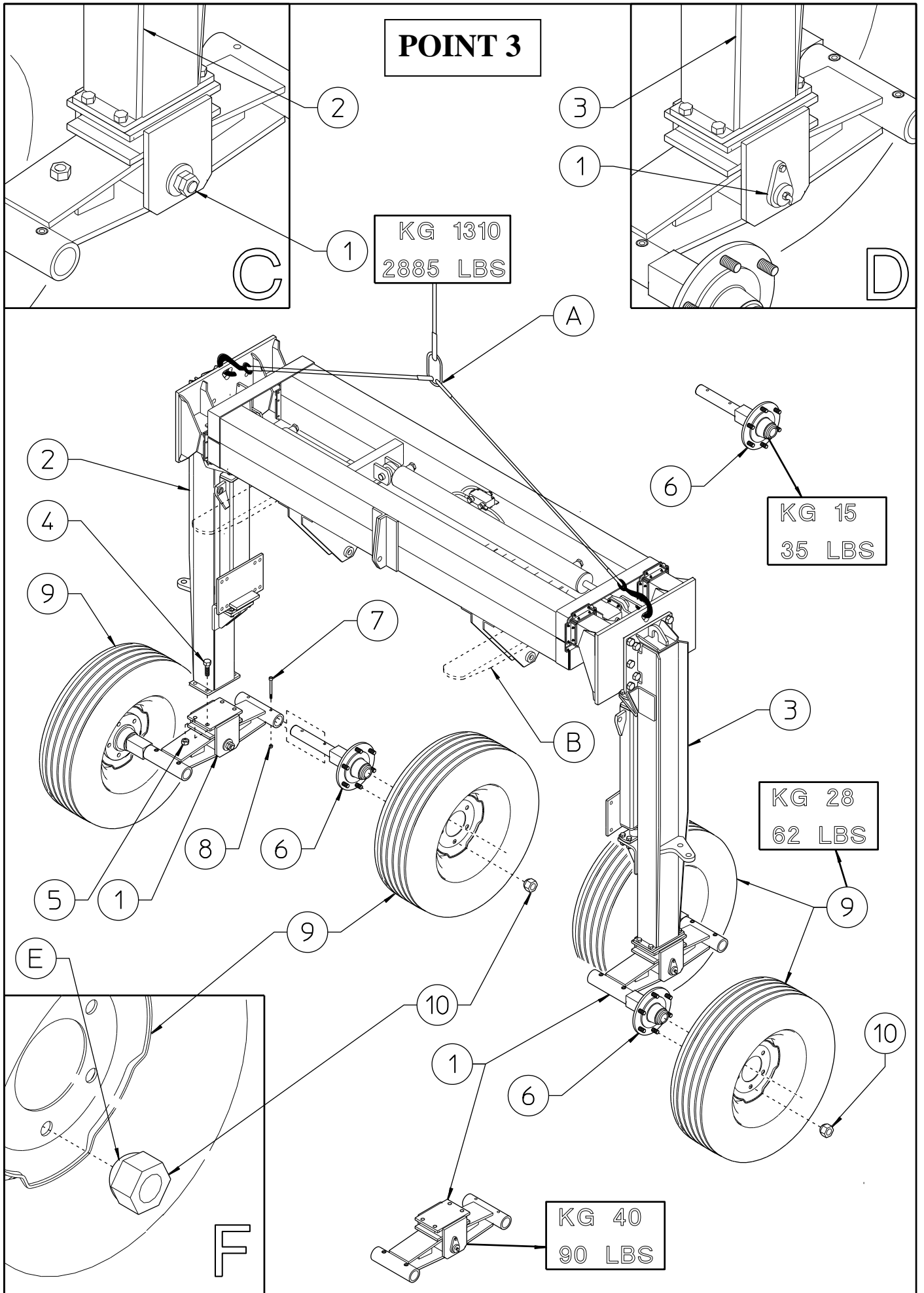

Point 3 (DANGER)

Keep the parts already assembled adequately raised using the lift A or B. Attach supports 1 to supports 2-3 (RH and LH) using bolts 4 and nuts 5. Support 1 attached to support 2 must appear as shown in box “C”, and support 1 attached to support 3 must appear as shown in box “D”. Assemble hubs 6 to supports 1 using bolts 7 and nuts 8. Attach the wheels 9 to the hubs 6 using nuts 10. Note: the rounded part “E” of nut 10 must face the rim of wheel 9 as shown in box “F”.

In this step, you will use:

- Item 4: 8 bolts M16x45 (0.63” x 1.77”)
- Item 5: 8 nuts M16 (0.63”)
- Item 7: 8 bolts M10x70 (0.39” x 2.75”)
- Item 5: 8 nuts M10 (0.39”)
- Item 10: 24 nuts M18x1.5 (0.71” x 0.06”)

POINT 4

KG 1430
3150 LBS

KG 75
165 LBS

KG 75
165 LBS

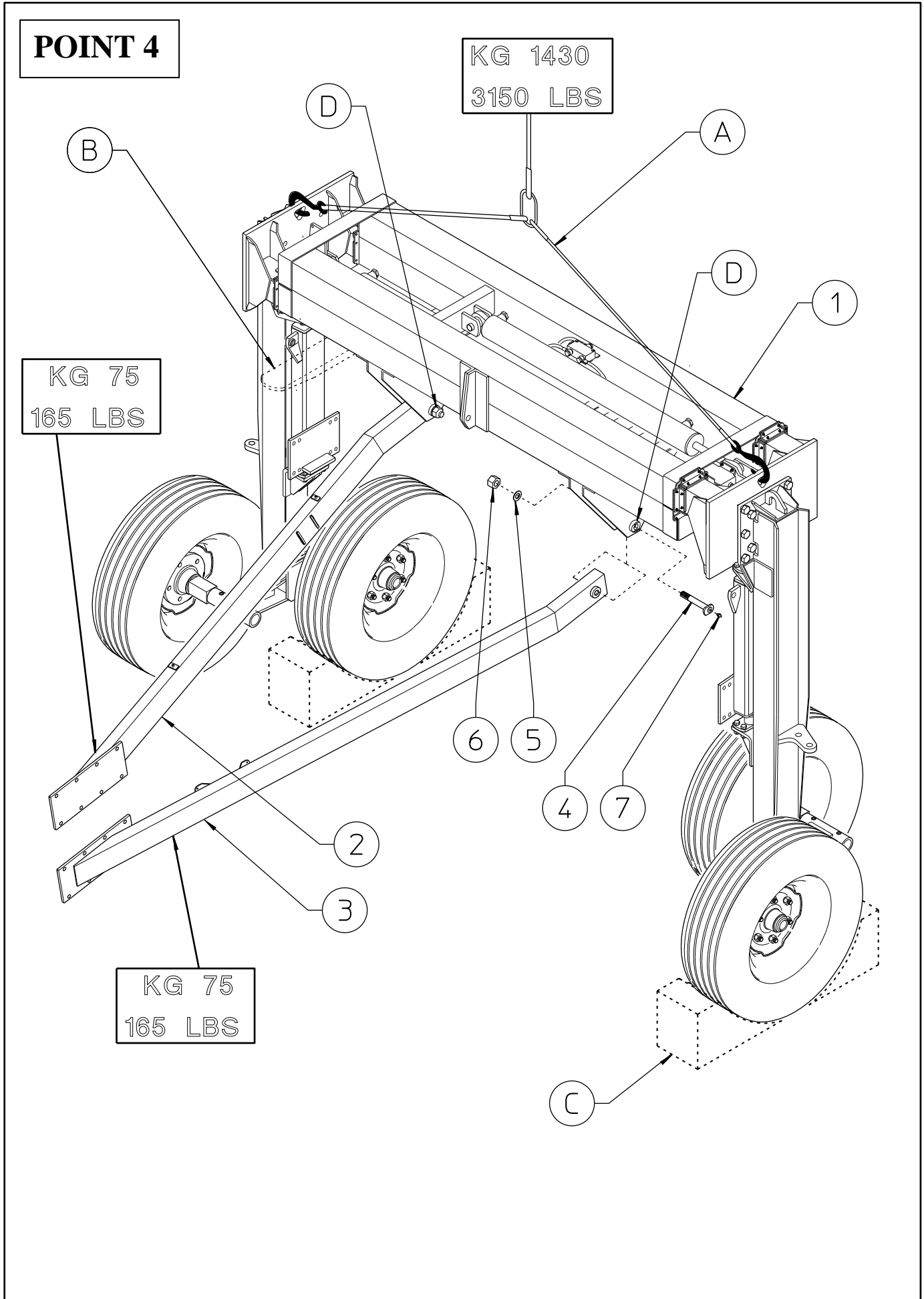

Point 4 (DANGER)

Keep the parts already assembled adequately balanced using the lift A or B.

To improve the stability of the parts assembled, chock the wheels with chocks “C”.

Note: from this point on the parts to be added no longer weigh directly on the lift, which now serves mainly to keep assembly 1 balanced, as it rests on the ground with the wheels. If you wish to keep assembly 1 raised above the ground to facilitate assembly or for other reasons, you must consider the weight that will be added bit by bit so as not to exceed the limits of the lift. Attach drawbars 2-3 (RH and LH) to points “D” on the crosspiece assembly 1 using the pins 4, washers 5 and nuts 6. Attach the grease nipples 7 to the pins 4.

In this step, you will use:

- Item 4: 2 pins $\varnothing 30 \times 134$ (1.18” x 5.27”)
- Item 5: 2 washers $\varnothing 25$ (1”)
- Item 6: 2 nuts M24 (0.94”)
- Item 7: 2 grease nipples M8 (0.31”)

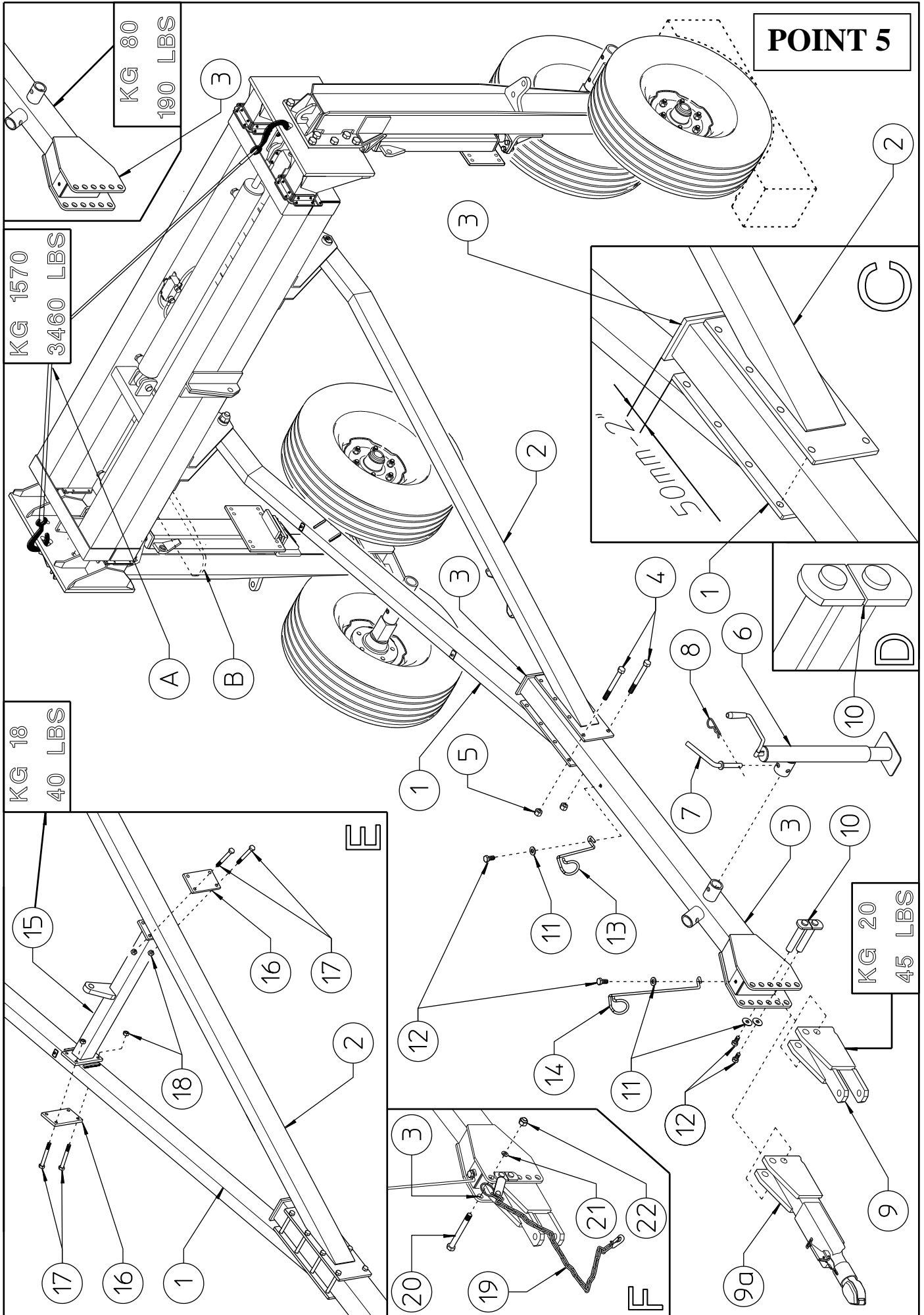

Point 5 (DANGER)

Keep the parts already assembled adequately balanced using the lift A or B.

Attach the front drawbar 3 between drawbars 1-2 (RH and LH) at the measure of about 50 mm – 2” using bolts 4 and nuts 5 (see box “C”). This measure allows normal operation but it can be adapted for the various needs of the user depending on the type of tractor used, the land to be worked, etc.

Attach the parking stand 6 to the drawbar 3 using pin 7 and pin 8. Attach the tractor hitch 9 or 9a (**9a OPTIONAL**) to drawbar 3 using pins 10, washers 11 and screws 12. Pins 10 must be placed as shown in box “D”. Attach the hose brackets 13-14 to their respective positions on the drawbar 3 using washers 11 and screws 12. Attach the drawbar crosspiece 15 (see box “E”) to drawbars 1-2 (RH and LH) using the counterplates 16, bolts 17 and nuts 18. Attach the safety chain 19 to the holes in the drawbar 3 using the bolt 20, washer 21 and nut 22.

In this step, you will use:

- Item 4: 8 bolts M16x145 (0.63” x 5.71”)
- Item 5: 8 nuts M16 (0.63”)
- Item 7: 1 pin \varnothing 15x78 (0.59” x 3.07”)
- Item 8: 1 pin \varnothing 3 (0.12”)
- Item 10: 2 pins \varnothing 25x125 (1” x 5”)
- Item 11: 4 washers \varnothing 12-40 x 4 (\varnothing 0.47” – 1.57” x 0.16”)
- Item 12: 4 screws M12 x 25 (0.47” x 1”)
- Item 17: 8 bolts M14x100 (0.55” x 4”)
- Item 18: 8 nuts M14 (0.55”)
- Item 20: 1 bolt M22x150 (0.87”x5.91”)
- Item 21: 1 split washer \varnothing 23 (\varnothing 0.91”)
- Item 22: 1 nut M22 (0.87”)

POINT 6

KG 1600
3525 LBS

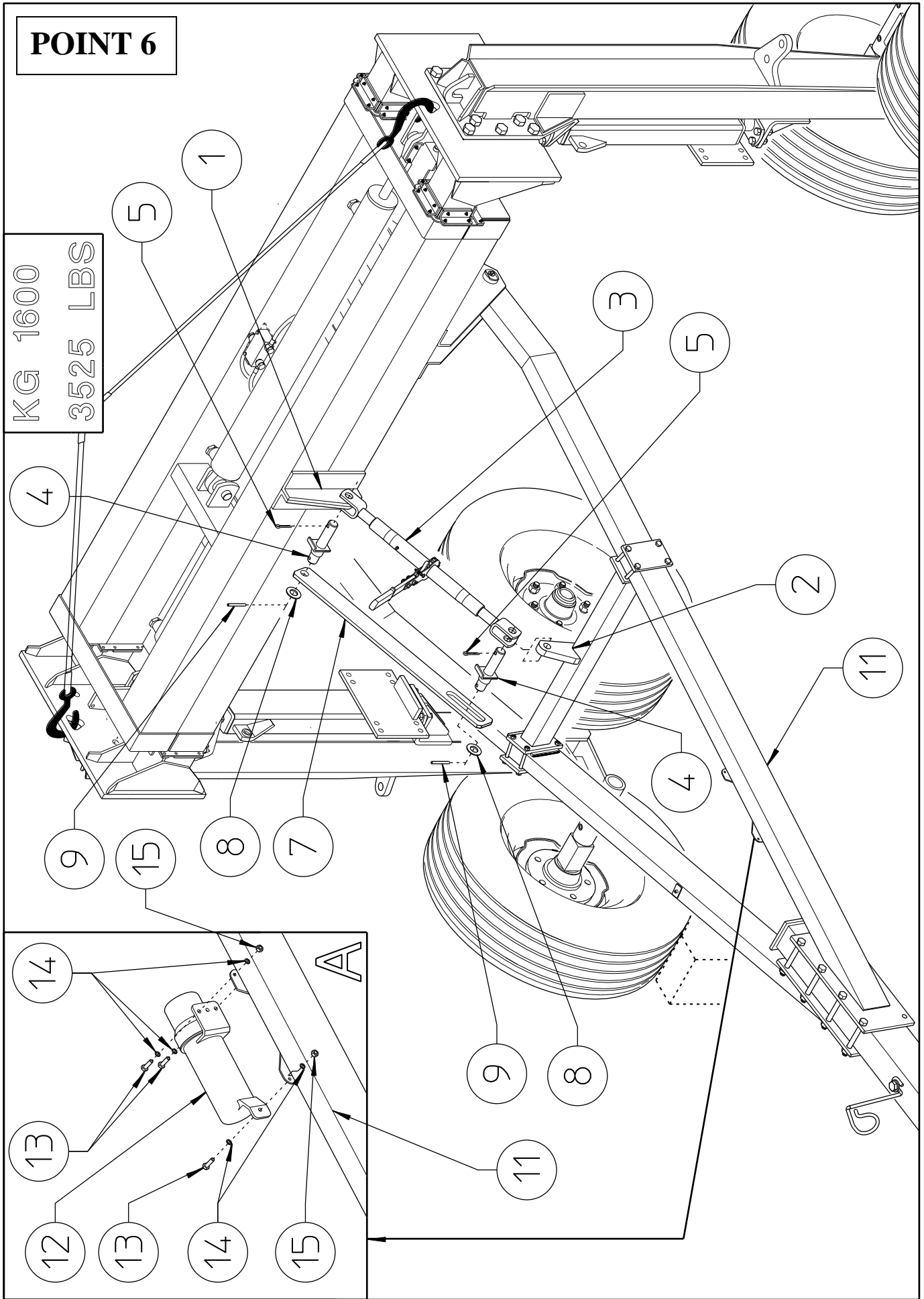

Point 6 (DANGER)

The assembly done so far gives the machine good stability; however, proceed with caution.

Attach the ratchet link 3 to the bracket 1 on the crosspieces assembly and to bracket 2 on the drawbar crosspiece using pins 4 and split pins 5. Attach the safety arm 7 to the free ends of pins 4 and fasten with the washers 8 and spring pins 9. Attach the manual canister 12 to the drawbar at point 11 (see box “A”) using bolts 13, washers 14 and nuts 15. Note: all manuals and other documents regarding the machine must be placed in the manual canister 12 so that they may be consulted at any time.

In this step, you will use:

- Item 4: 2 pins $\varnothing 25\text{-}\varnothing 30 \times 134$ ($\varnothing 1'' - \varnothing 1.18'' \times 5.27''$)
- Item 5: 2 split pins $\varnothing 6 \times 35$ ($0.24'' \times 1.38''$)
- Item 8: 2 washers $\varnothing 25$ ($1''$)
- Item 9: 2 spring pins $\varnothing 8 \times 40$ ($0.31'' \times 1.57''$)
- Item 13: 3 bolts $M6 \times 20$ ($0.24'' \times 0.79''$)
- Item 14: 6 washers $\varnothing 6.6\text{-}18 \times 2$ ($\varnothing 0.26'' - 0.71'' \times 0.08''$)
- Item 15: 3 nuts $M6$ ($0.24''$)

POINT 7

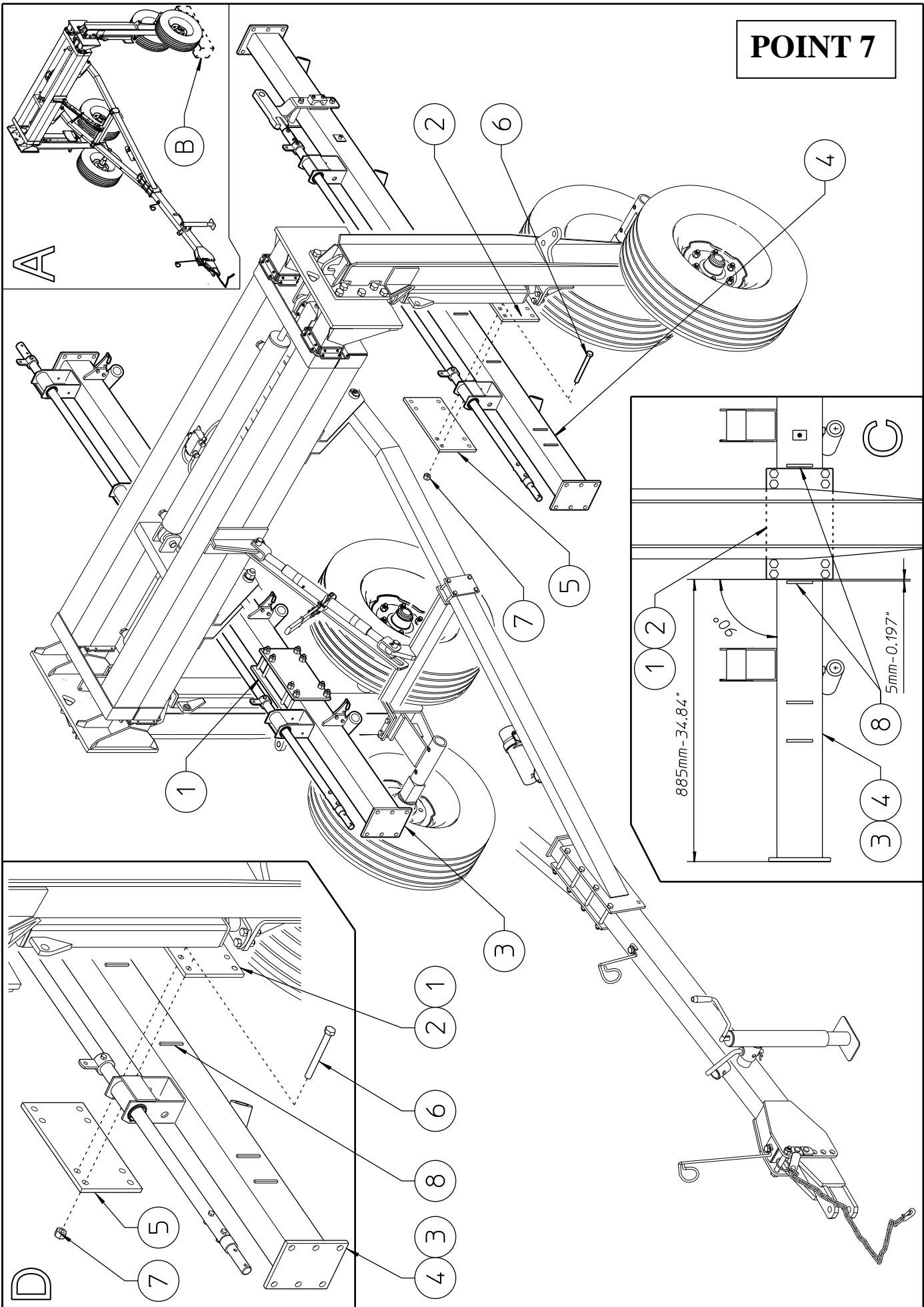

Point 7 (ATTENTION)

The assembly done so far (see box “A”) gives the machine full stability, therefore the lifts can be removed. Do not remove chocks “B” from the wheels. Continue assembly using maximum caution.

Attach the sections 3-4 (RH and LH) to the supports 1-2 using the counterplates 5, bolts 6 and nuts 7. The support plates 1-2 must be placed between the reference plates 8 (see boxes “C” and “D”) of sections 3-4 and the free space between plates 8 must be the same on each side (5 mm-0.197”, see box “C”); sections 3-4 (RH and LH) must be horizontal to the ground (at 90° in relation to the support plates 1-2, see box “C”).

In this step, you will use:

- Item 6: 16 bolts M16x130 (0.63” x 5.12”)
- Item 7: 16 nuts M16 (0.63”)

POINT 8

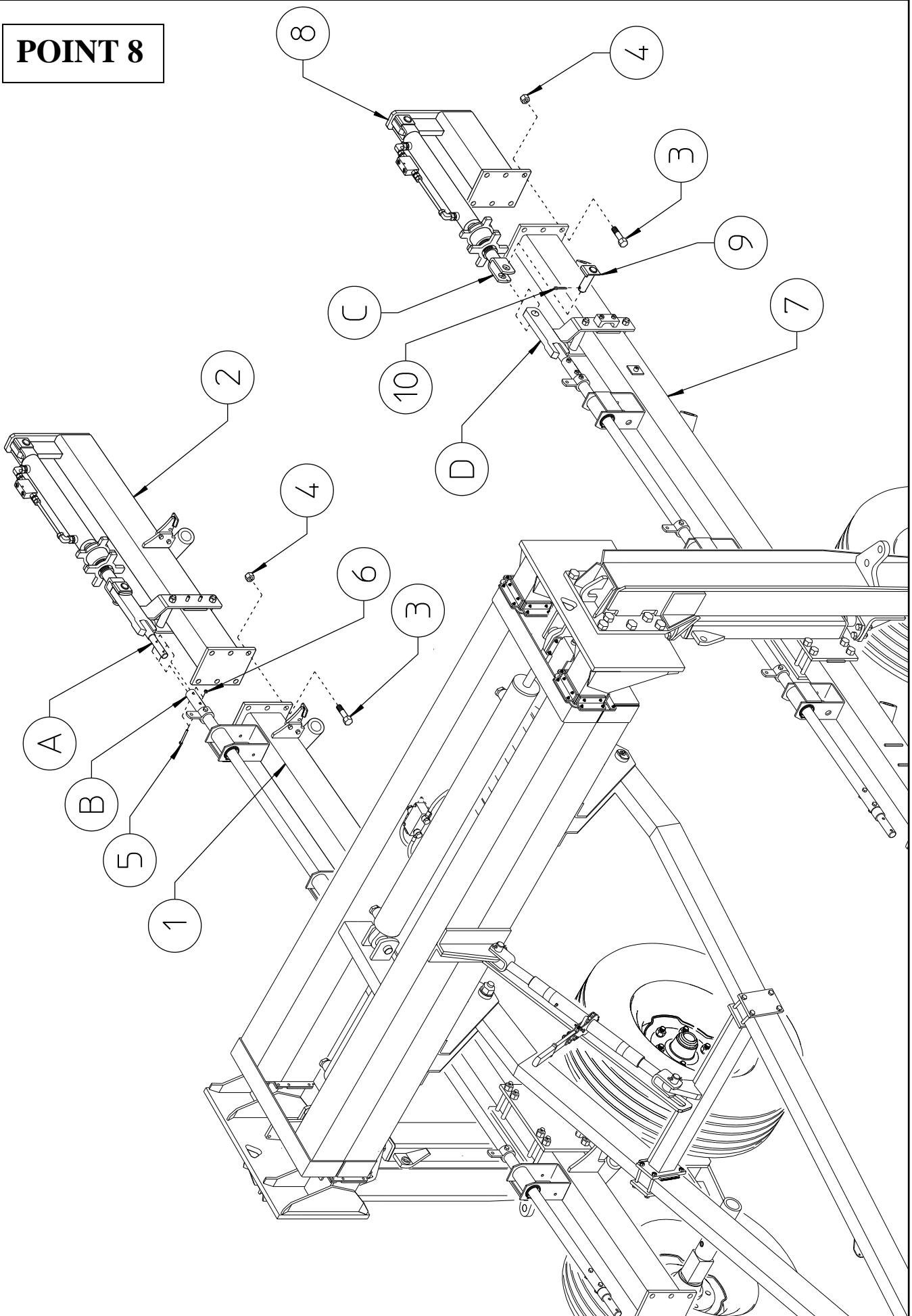

Point 8 (ATTENTION)

Continue assembly using maximum caution.

Note: in some cases, for packing necessities or to facilitate assembly, screws, bolts, washers, nuts and accessories have been preassembled by the manufacturer, and therefore they must be removed in order to carry out the assembly. The parts not preassembled are found in the nuts & bolts bag and/or in the assembly boxes. This note holds true also for the following stages.

Attach the support with the cylinder and accessories 2 to the RH section 1 using bolts 3 and nuts 4. Fasten pin “A” of support 2 to the tube “B” on section 1 using bolts 5 and nuts 6. Attach the support with the cylinder and accessories 8 to the LH section 7 using bolts 3 and nuts 4. Fasten connector “C” on the cylinder of support 8 to the connector “D” on section 7 using the pin 9 and the split pin 10.

In this step, you will use:

- Item 3: 8 bolts M16x45 (0.63” x 1.77”)
- Item 4: 8 nuts M16 (0.63”)
- Item 5: 2 bolts M8x45 (0.31” x 1.77”)
- Item 6: 2 nuts M8 (0.31”)
- Item 9: 1 pin $\varnothing 25 \times 50$ ($\varnothing 1$ ” x 2”)
- Item 10: 2 split pins $\varnothing 6 \times 35$ (0.24” x 1.38”)

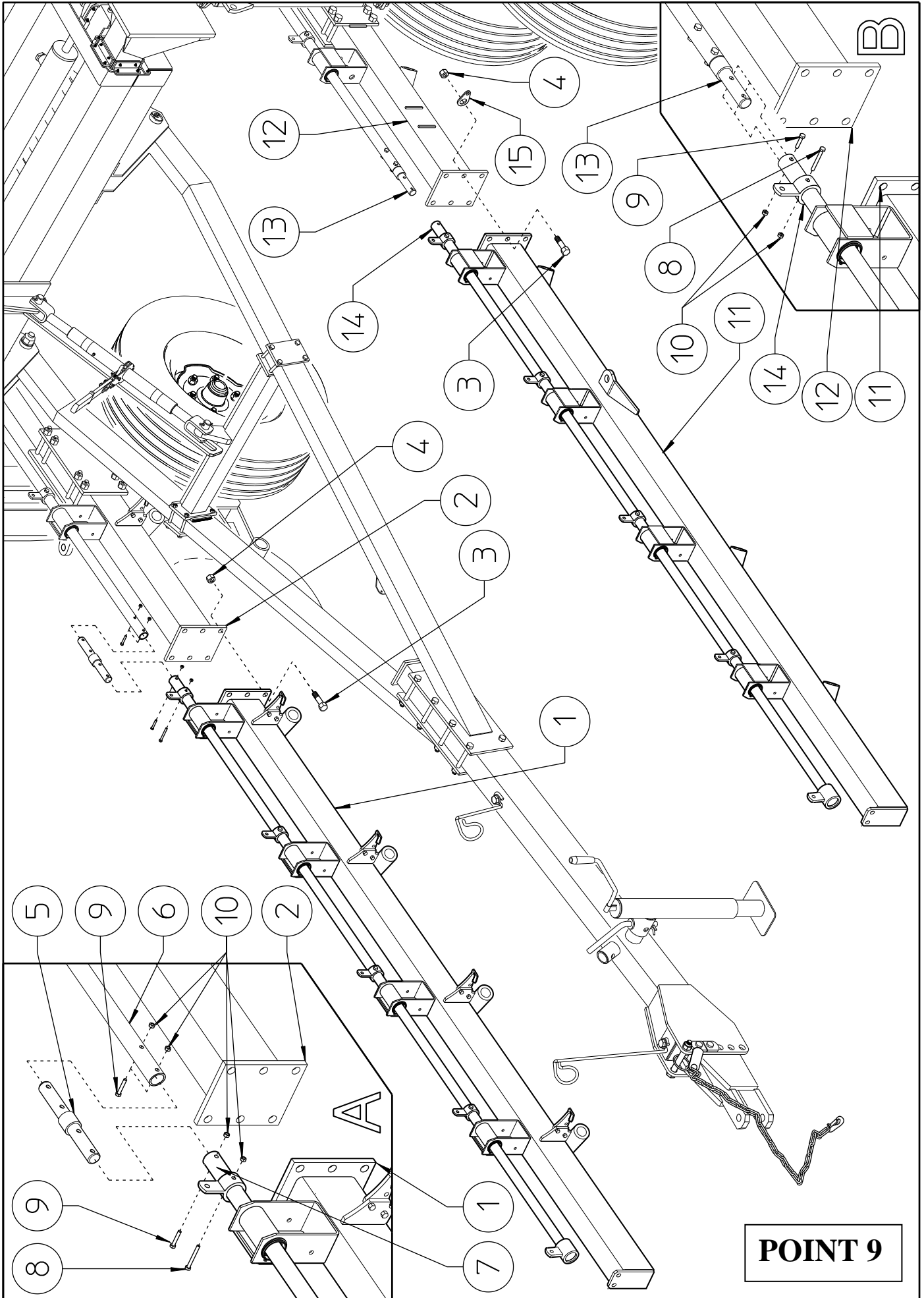

Point 9 (ATTENTION)

Continue assembly using maximum caution.

Attach RH section 1 to RH section 2 using bolts 3 support 15 and nuts 4. Connect tube 6 on section 2 to tube 7 on section 1 by means of pin 5 (see box "A") using bolts 8-9 and nuts 10. Attach LH section 11 to LH section 12 using bolts 3 and nuts 4. Connect pin 13 (see box "B") of section 12 to tube 14 of section 11 using bolts 8-9 and nuts 10.

In this step, you will use:

- Item 3: 8 bolts M16x45 (0.63" x 1.77")
- Item 4: 8 nuts M16 (0.63")
- Item 8: 2 bolts M8x60 (0.31" x ")
- Item 9: 4 bolts M8x45 (0.31" x 1.77")
- Item 10: 6 nuts M8 (0.31")

POINT 10

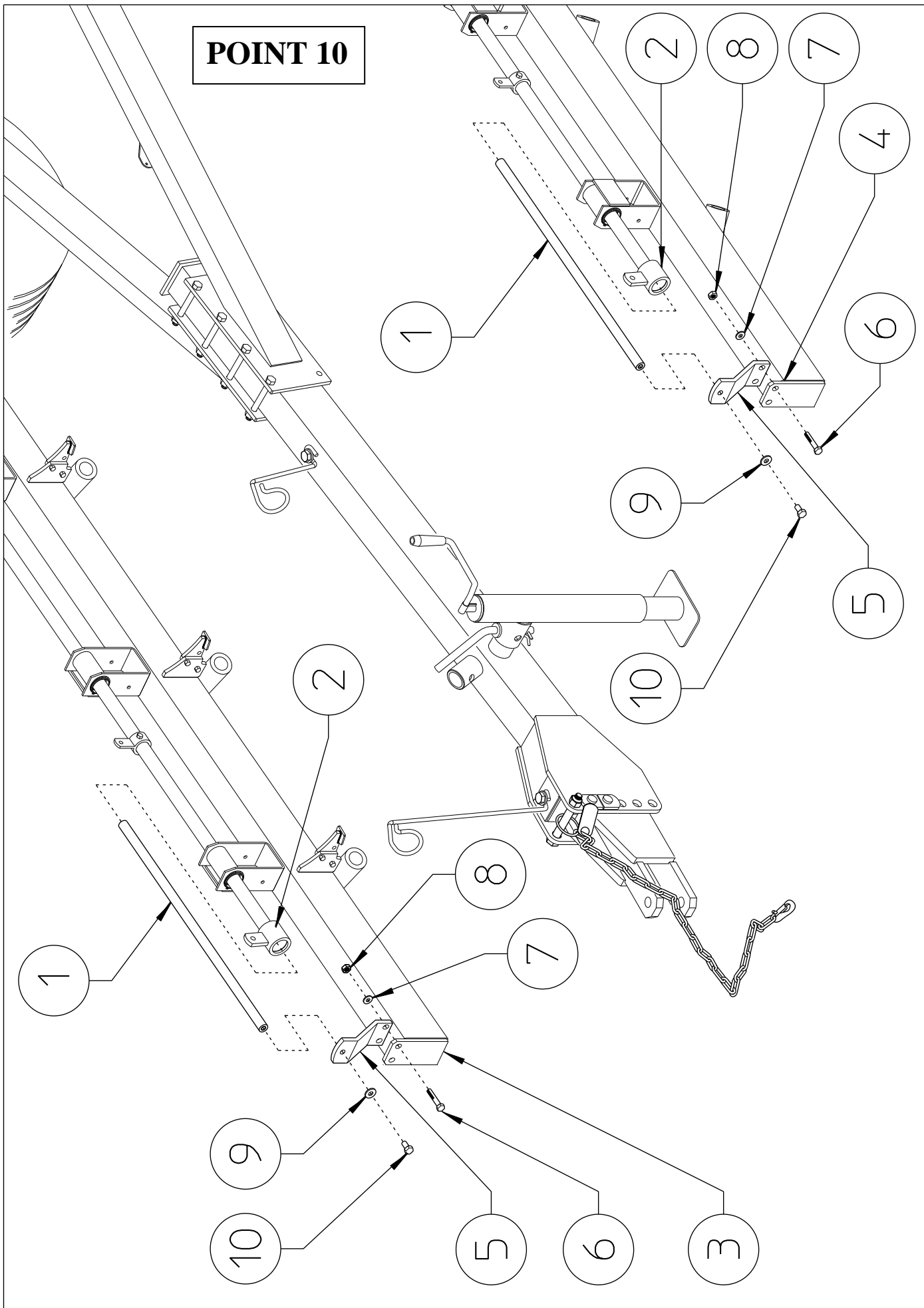

Point 10 (ATTENTION)

Continue assembly using maximum caution.

Insert pins 1 into opening 2 in the tubes on sections 3-4 (RH and LH). Attach brackets 5 to the ends of sections 3-4 using screws 6, washers 7 and nuts 8. Join pins 1 to brackets 5 using the washers 9 and screws 10.

In this step, you will use:

- Item 6: 4 screws M10x35 (0.39" x 1.38")
- Item 7: 4 washers \varnothing 10.5 (0.41")
- Item 8: 4 nuts M10 (0.39")
- Item 9: 4 spring washers \varnothing 10.5 (0.41")
- Item 10: 4 screws M12x20 (0.47" x 0.79")

POINT 11

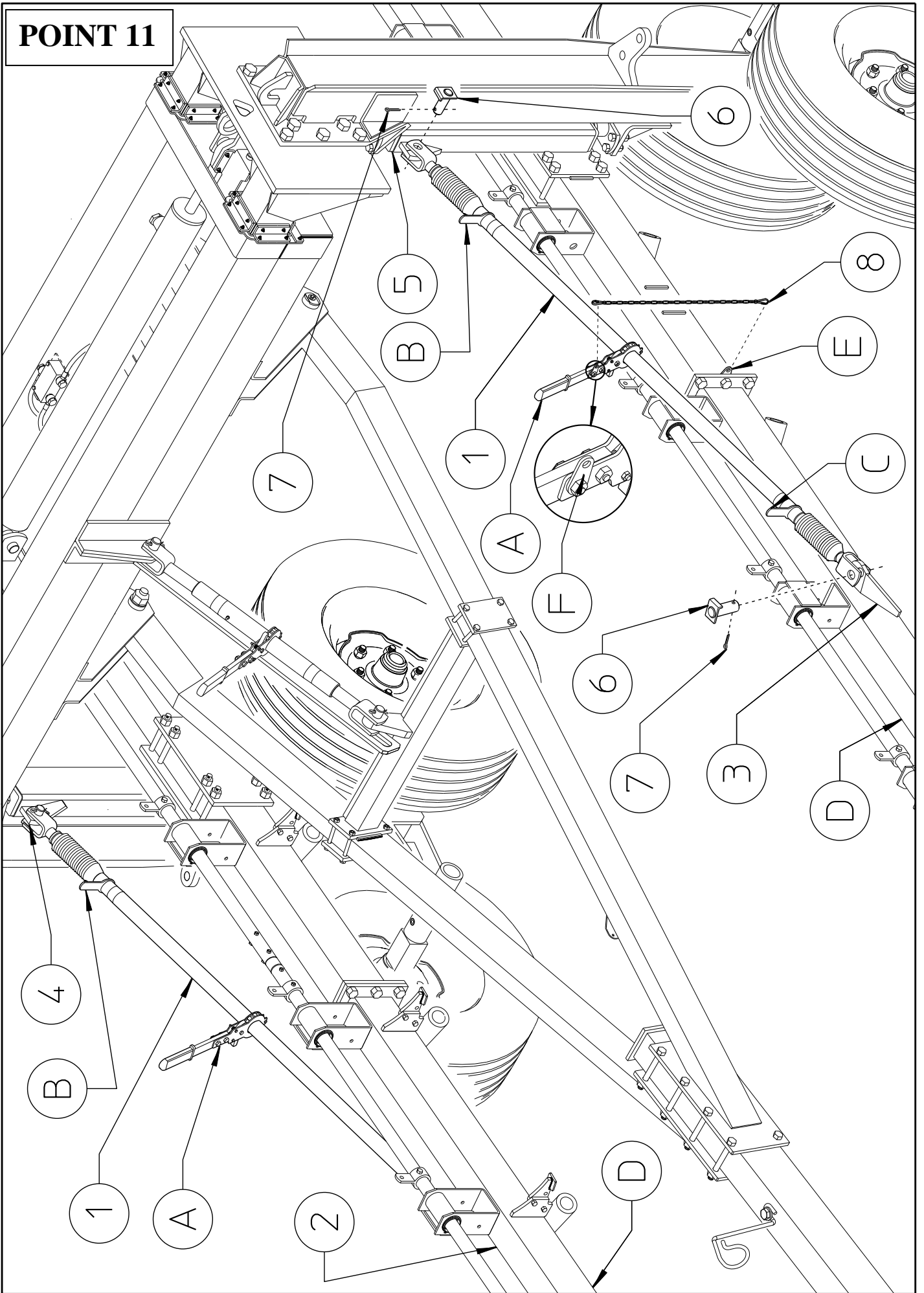

Point 11 (ATTENTION)

Continue assembly using maximum caution.

Attach the ratchet links 1 to sections 2-3 (RH and LH) and to brackets 4-5 (RH and LH) using the pins 6 and split pins 7.

If the ratchet links do not couple perfectly to brackets 2-3-4-5, loosen clamps B-C and move lever A to adjust them to the right length. Once the ratchet link 1 is correctly assembled, move lever A so that sections 2-3 are raised slightly on side "D", then retighten clamps B-C.

Attach the chain 8 to the two supports E-F.

In this step, you will use:

Item 6: 4 pins $\varnothing 25 \times 50$ ($\varnothing 1'' \times 2''$)

Item 7: 4 split pins $\varnothing 6 \times 35$ ($0.24'' \times 1.38$)

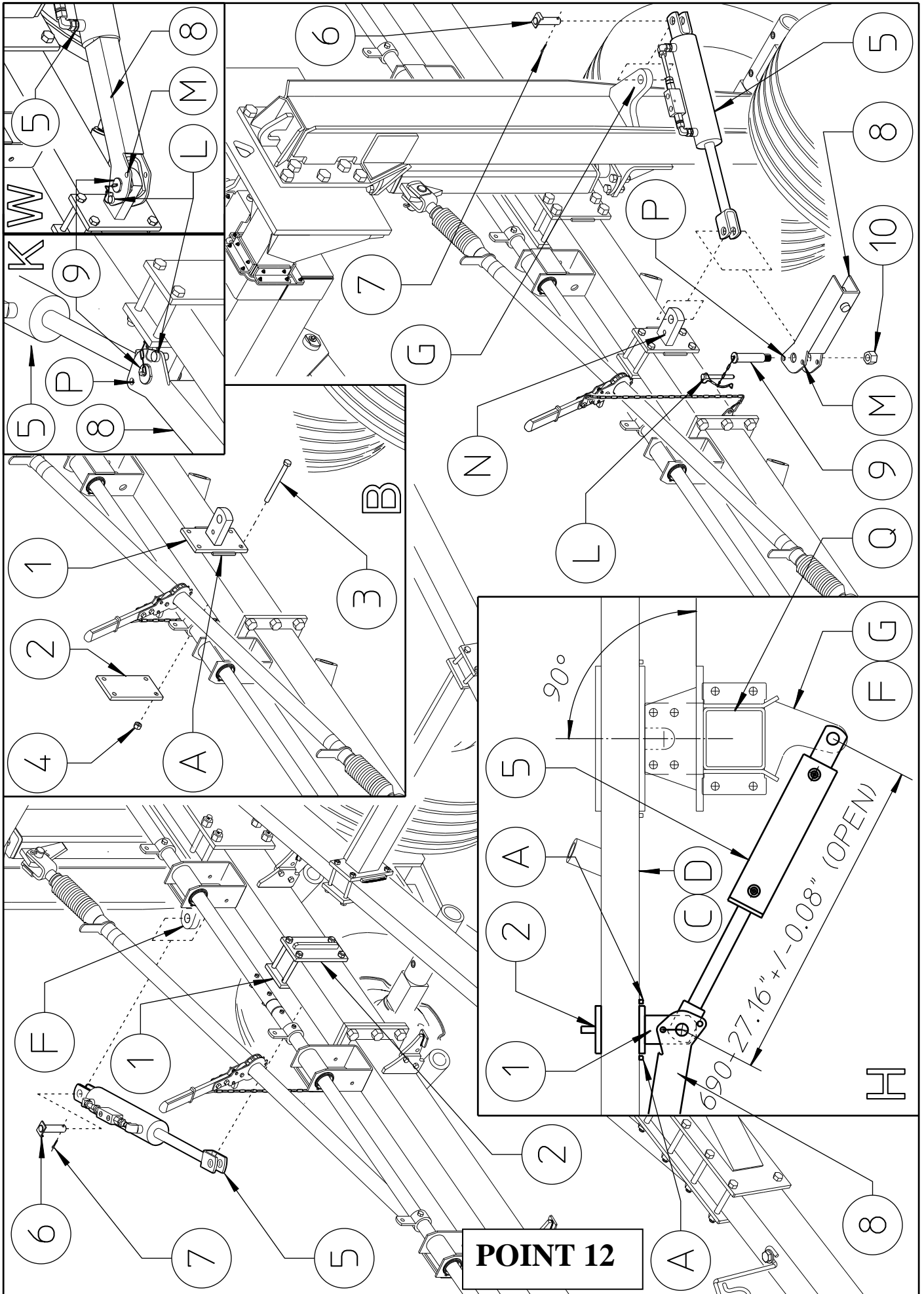

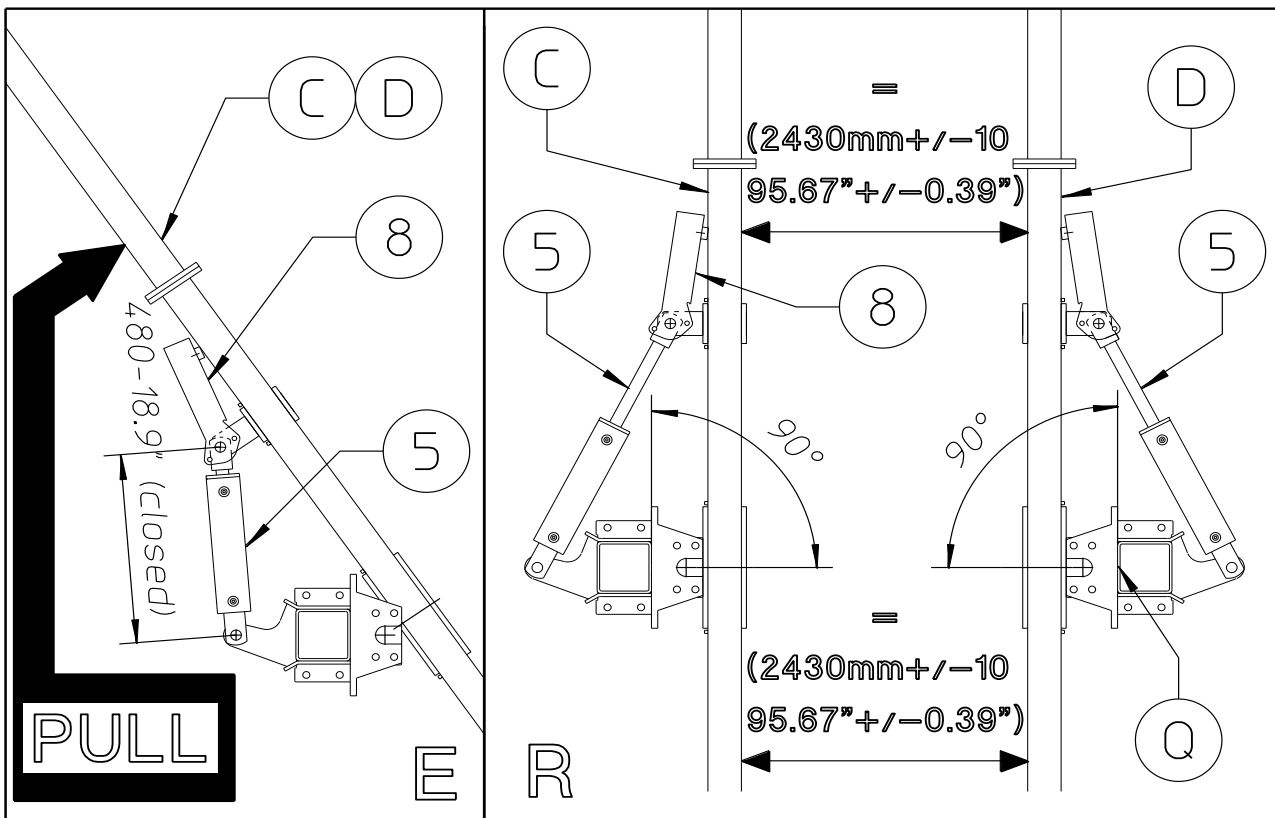

Point 12 (ATTENTION)

Continue assembly using maximum caution.

Attach brackets 1 between the position notches A (see also boxes “B”- “H”) using counterplates 2, bolts 3 and nuts 4. At this time do not tighten fully nuts 4. Now remove the caps (be careful not to allow dirt to enter) placed over the valves of cylinders 5 and extend the cylinders completely up to the length of 690 mm +/-2 – 27.16” +/- 0.08”. Note: even when the caps are removed, it may be difficult to open the cylinder because the block valve partially opposes the passage of air. In this case the cylinder shaft must be tugged until it extends completely. If this does not work, attach the closed cylinder 5 (480 mm-18.9”) according to the method indicated in following and use section “C” or “D” as a lever to extend it (see box “E”).

Attach the cylinders 5 to the brackets 1 and supports F-G (RH and LH). Fasten cylinders 5 to their supports F-G using pins 6 and split pins 7. Attach transport retainers 8 to the side of the cylinders 5 that goes to brackets 1 and lock all in place with pins 9 and nuts 10. (See also boxes “H”-“K”.) Lever 8 should be positioned as shown in the drawing in box “K” by inserting pin L (integral with pin 9) into holes M in the lever and N in bracket 1. This is the position to be used while working and also during assembly. Lever 8 should be positioned as shown in the drawing in box “W” by inserting pin L into holes P in the lever and N in bracket 1. This is the position to be used during transport.

Before fully tightening the nuts 4 make sure that sections “C” – “D” are parallel with each other or 90° with respect to the axis of piece “Q” (see boxes “H”- “R”). If these conditions do not occur, move bracket 1 forward or backward between notches A until the required position is reached. At this point fully tighten the nuts 4.

In this step, you will use:

- Item 3: n° 8 screw M12x120 (0.47“ x 4.72”)
- Item 4: n° 8 nut M12 (0.47”)
- Item 6: n° 2 pin ø25x50 (ø1“ x 2”)
- Item 7: n° 2 split pin ø6x35 (0.24” x 1.38”)
- Item 9: n° 2 pin ø25x62 (ø1“ x 2.44”)
- Item 10: n° 2 Nut M20 (0.78”)

POINT 13

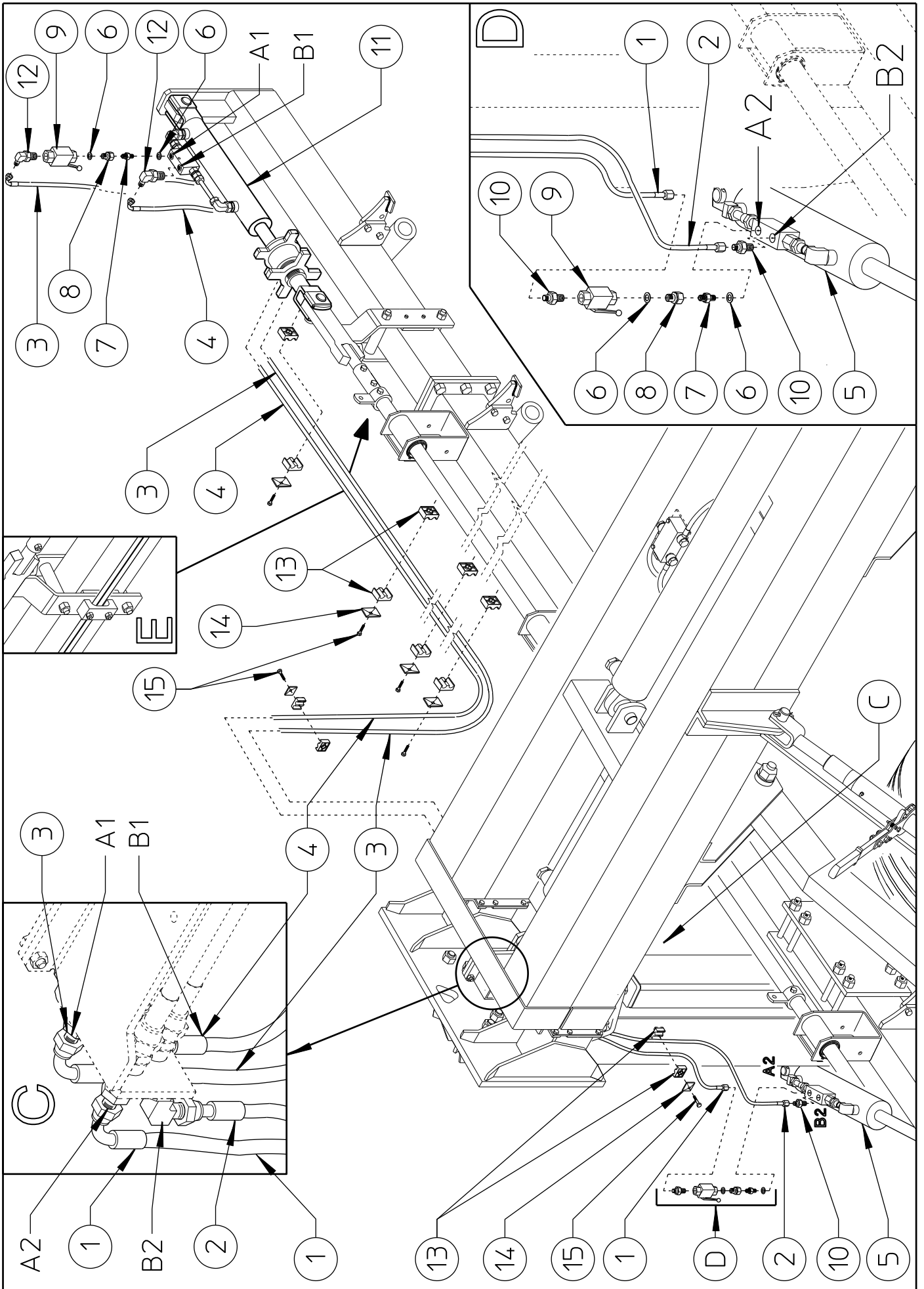

Point 13 (ATTENTION)

Prior to the assembly of arms, rake wheels and accessories, we recommend to assemble the hydraulic system in order to have more room to manoeuvre. Although the assembly of the hydraulic system requires attention, difficulties will be minimal because the most complex parts have been pre-assembled by the manufacturer.

The hoses 1-2-3-4 to be assembled in this step may be found partially pre-assembled in the area “C” of the crosspiece assembly.

Attach nipple 7 and washer 6 at point A2 on the valve of cylinder 5. Attach fitting 8 to the nipple 7. Attach valve 9 and washer 6 to the fitting 8. Attach fitting 10 to the valve 9. Attach fitting 10 at point B2 on the valve of cylinder 5 (see box D).

Attach hose 1 (the one that in box “C” has a 90° end already connected to attachment A2) to fitting 10 in position A2 on the valve. Attach hose 2 (the one that in box “C” is already connected to attachment B2) to fitting 10 in position B2 on the valve. Fasten hoses 1-2 in place using semi-collars 13, clamp 14 and screws 15.

First pass the hoses 3-4 through the bracket (see box “E”).

Attach nipple 7 and washer 6 at point A1 on the valve of cylinder 11. Attach fitting 8 to the nipple 7. Attach valve 9 and washer 6 to the fitting 8. Attach fitting 12 to the valve 9. Attach fitting 12 at point B1 on the valve of cylinder 11.

Attach hose 3 (the one that in box “C” has a 90° end already connected to attachment A1) to fitting 12 in position A1 on the valve. Attach hose 4 (the one that in box “C” is already connected to attachment B1) to fitting 12 in position B1 on the valve. Fasten hoses 3-4 in place using semi-collars 13, clamp 14 and screws 15.

In this step, you will use:

- Item 6: n° 4 washer $\varnothing 3/8''$
- Item 7: n° 2 nipple $3/8'' - 3/8''$
- Item 8: n° 2 fitting female $3/8'' - \text{male } 3/8''$
- Item 9: n° 2 valve $3/8''$
- Item 10: n° 2 fitting $3/8'' - 1/2''$ jic 37°
- Item 12: n° 2 fitting $90^\circ 3/8'' - 1/2''$ jic 37°
- Item 13: n° 12 semi-collar for $\varnothing 12$ ($\varnothing 0.47''$) tube
- Item 14: n° 6 clamp
- Item 15: n° 6 screw M6x35 ($0.23'' \times 1.38''$)

POINT 14

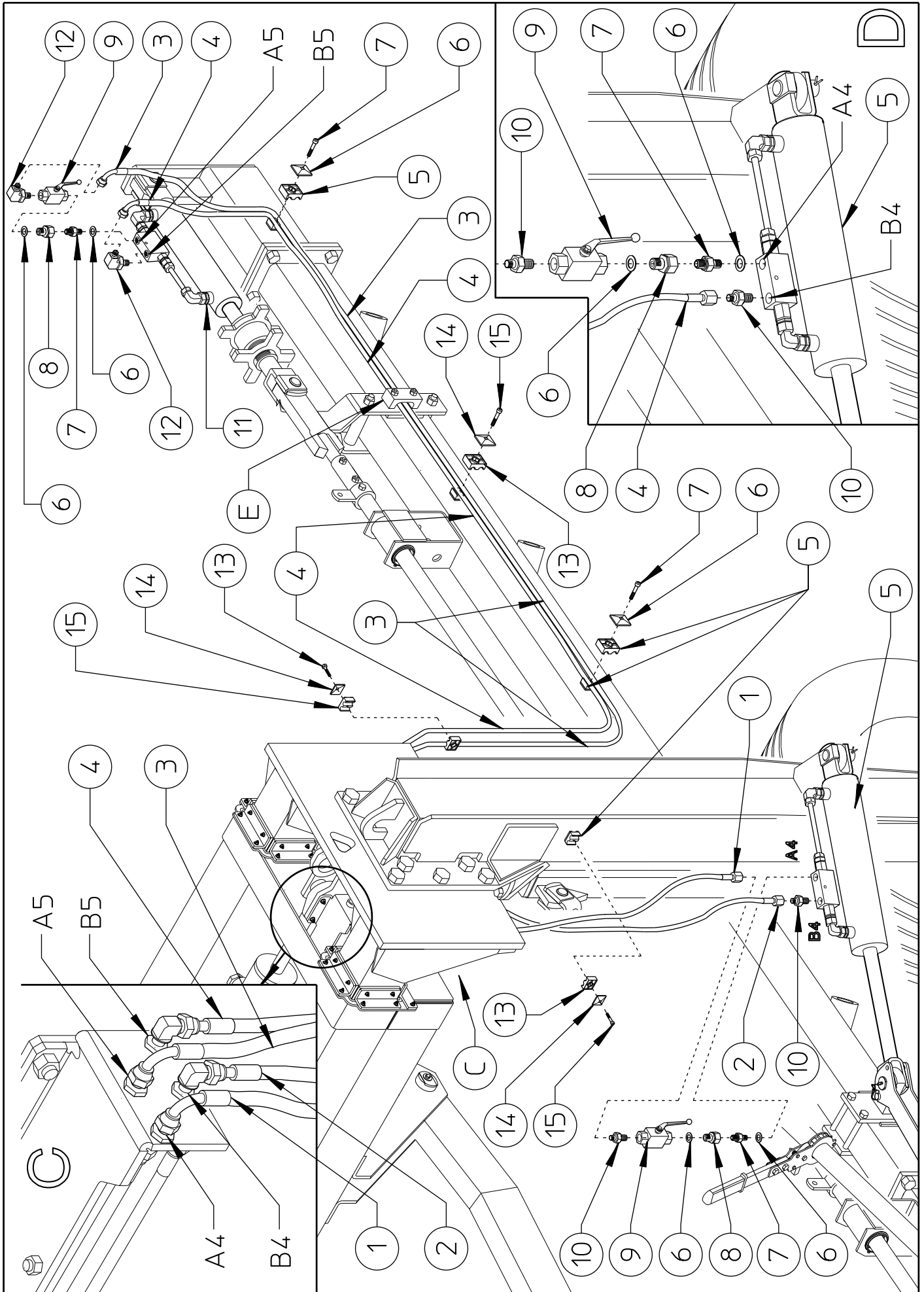

Point 14 (ATTENTION)

Prior to the assembly of arms, rake wheels and accessories, we recommend to assemble the hydraulic system in order to have more room to manoeuvre. Although the assembly of the hydraulic system requires attention, difficulties will be minimal because the most complex parts have been pre-assembled by the manufacturer.

The hoses 1-2-3-4 to be assembled in this step may be found partially pre-assembled in the area “C” of the crosspiece assembly.

Attach nipple 7 and washer 6 at point A4 on the valve of cylinder 5. Attach fitting 8 to the nipple 7. Attach valve 9 and washer 6 to the fitting 8. Attach fitting 10 to the valve 9. Attach fitting 10 at point B4 on the valve of cylinder 5 (see box D).

Attach hose 1 (the one that in box “C” has a 90° end already connected to attachment A4) to fitting 10 in position A4 on the valve. Attach hose 2 (the one that in box “C” is already connected to attachment B4) to fitting 10 in position B4 on the valve. Fasten hoses 1-2 in place using semi-collars 13, clamp 14 and screws 15.

First pass the hoses 3-4 through the bracket E.

Attach nipple 7 and washer 6 at point A5 on the valve of cylinder 11. Attach fitting 8 to the nipple 7. Attach valve 9 and washer 6 to the fitting 8. Attach fitting 12 to the valve 9. Attach fitting 12 at point B5 on the valve of cylinder 11.

Attach hose 3 (the one that in box “C” has a 90° end already connected to attachment A5) to fitting 12 in position A5 on the valve. Attach hose 4 (the one that in box “C” is already connected to attachment B5) to fitting 12 in position B5 on the valve. Fasten hoses 3-4 in place using semi-collars 13, clamp 14 and screws 15.

In this step, you will use:

- Item 6: n° 4 washer $\varnothing 3/8''$
- Item 7: n° 2 nipple $3/8'' - 3/8''$
- Item 8: n° 2 fitting female $3/8'' - \text{male } 3/8''$
- Item 9: n° 2 valve $3/8''$
- Item 10: n° 2 fitting $3/8'' - 1/2''$ jic 37°
- Item 12: n° 2 fitting $90^\circ 3/8'' - 1/2''$ jic 37°
- Item 13: n° 12 semi-collar for $\varnothing 12$ ($\varnothing 0.47''$) tube
- Item 14: n° 6 clamp
- Item 15: n° 6 screw M6x35 ($0.23'' \times 1.38''$)

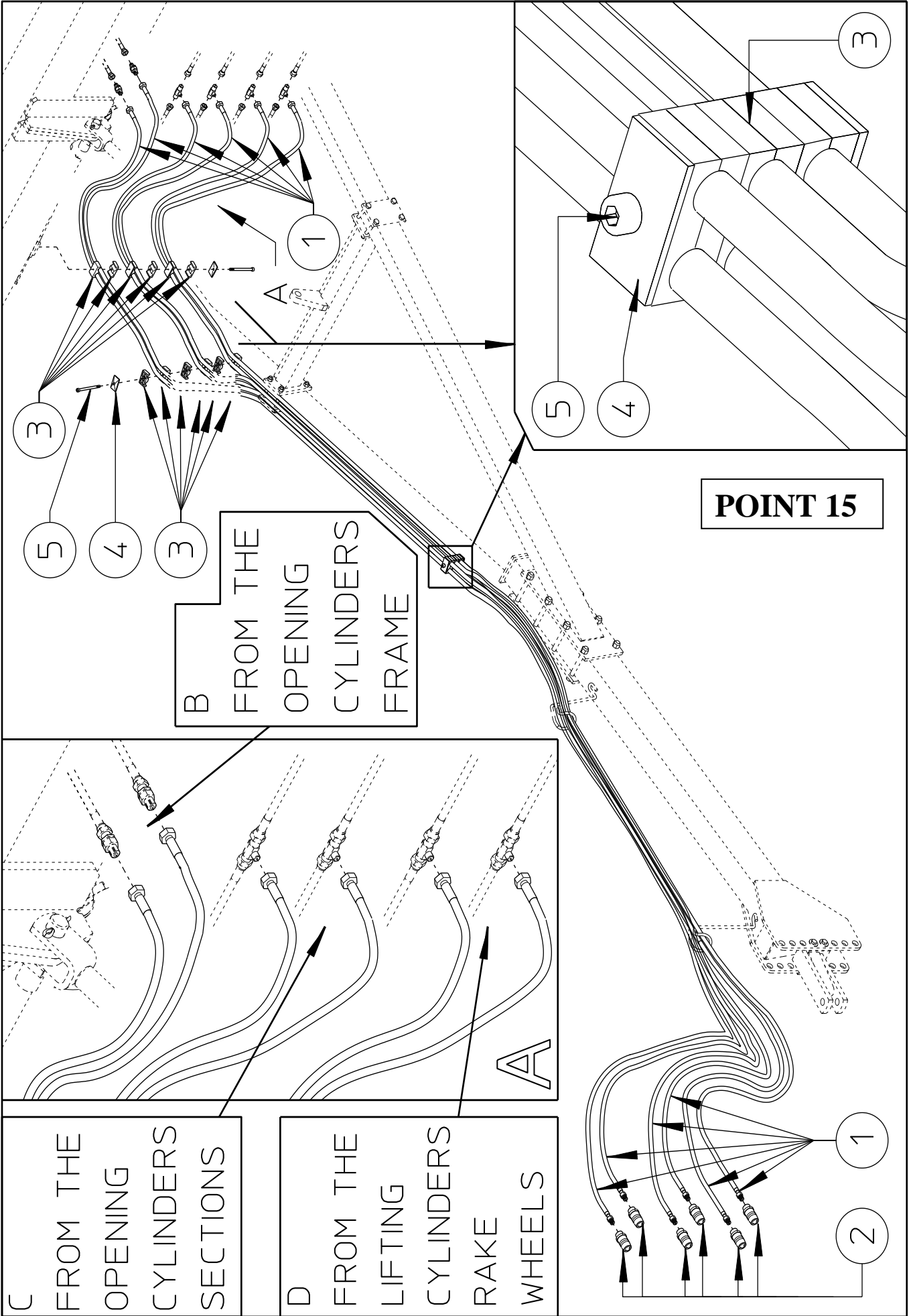

Point 15 (ATTENTION)

Attach the female end of hoses 1 to the couplings B-C-D in area A of the frame. Attach two hoses 1 to couplings B, two to couplings C and two to couplings D.

Lay hoses 1 all along the drawbar.

Attach quick couplings 2 to the ends of hoses 1. Note: to avoid problems with leaks, apply Loctite between the hoses 1 and quick couplings 2.

Then fasten hoses 1 to the respective openings using semi-collars 3, clamps 4 and screws 5.

In this step, you will use:

- Item 1: n° 6 hose 3/8" 1.7500 (295.27")
- Item 2: n° 6 rapid coupling 1/2"
- Item 3: n° 18 semi-collar for ø18 (ø0.71") tube
- Item 4: n° 3 clamp
- Item 5: n° 3 screw M8x95 (0.31"x3.74")

POINT 16

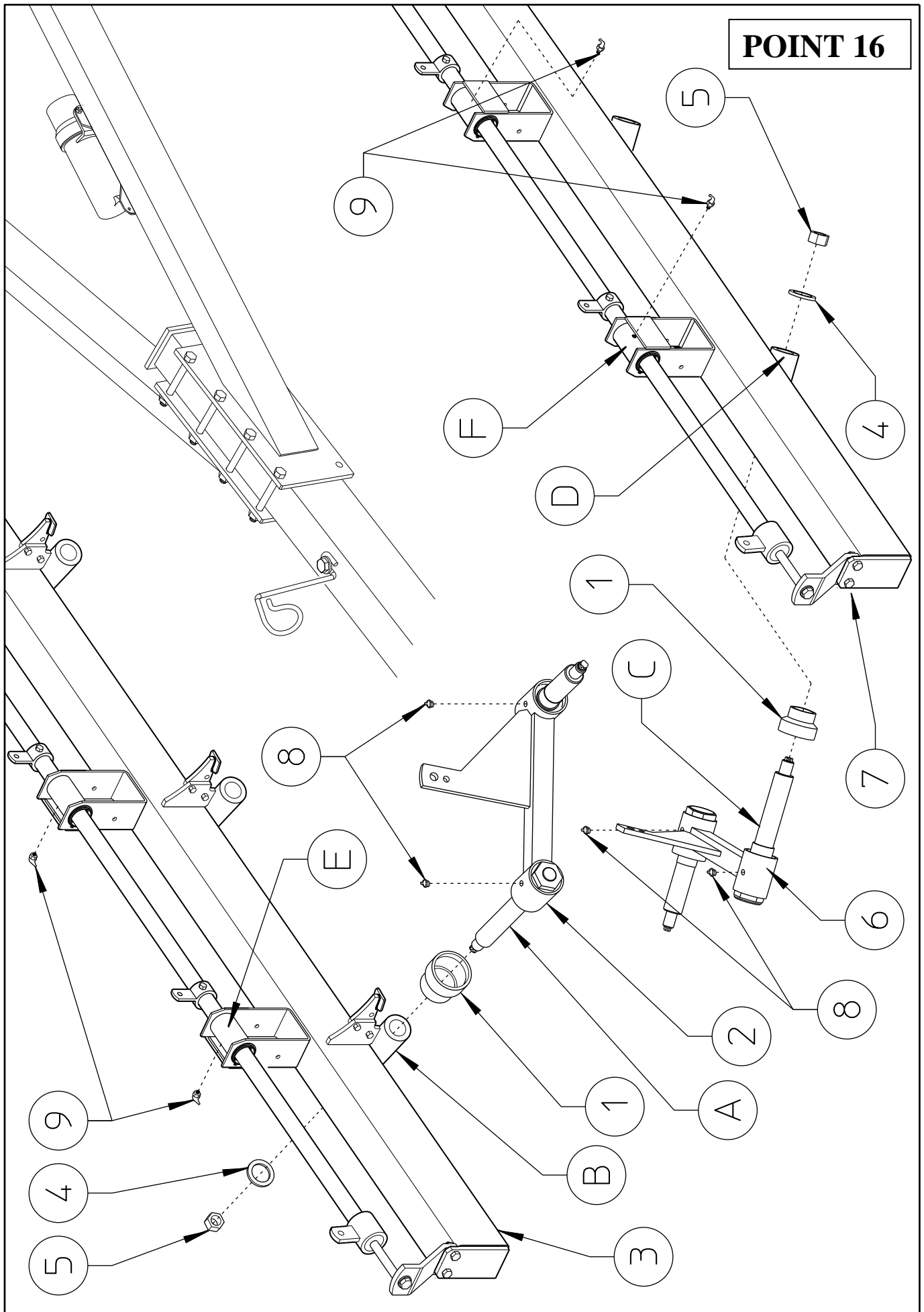

Point 16 (ATTENTION)

Attach protection 1 on pin “A” (the longer of the two) of RH arm 2. Attach pin “A” of RH arm 2 on the respective opening “B” of RH section 3. Fasten RH arm 2 to the opening “B” using washer 4 and nut 5 (the RH arms 2 to be connected to the openings “B” of RH section 3 are nine.)

Attach protection 1 on pin “C” (the longer of the two) of LH arm 6. Attach pin “C” of LH arm 6 to the opening “D” of LH section 7. Fasten LH arm 6 to opening “D” using washer 4 and nut 5 (the LH arms 6 to be connected to the openings “D” of LH section 7 are eight).

Assemble nipples 8 on the openings of arms 2-6 (RH and LH). Assemble nipples 9 on the openings “E-F” of sections 3-7 (RH and LH).

In this step, you will use:

Item 4: n° 17 \emptyset 23-50x4 (\emptyset 0.91”-1.97”x0.16”)

Item 5: n° 17 nut M22 (0.87”)

Item 8: n° 34 grease nipple M6 (0.24”)

Item 9: n° 17 grease nipple M6 x 45° (0.24” x 45°)

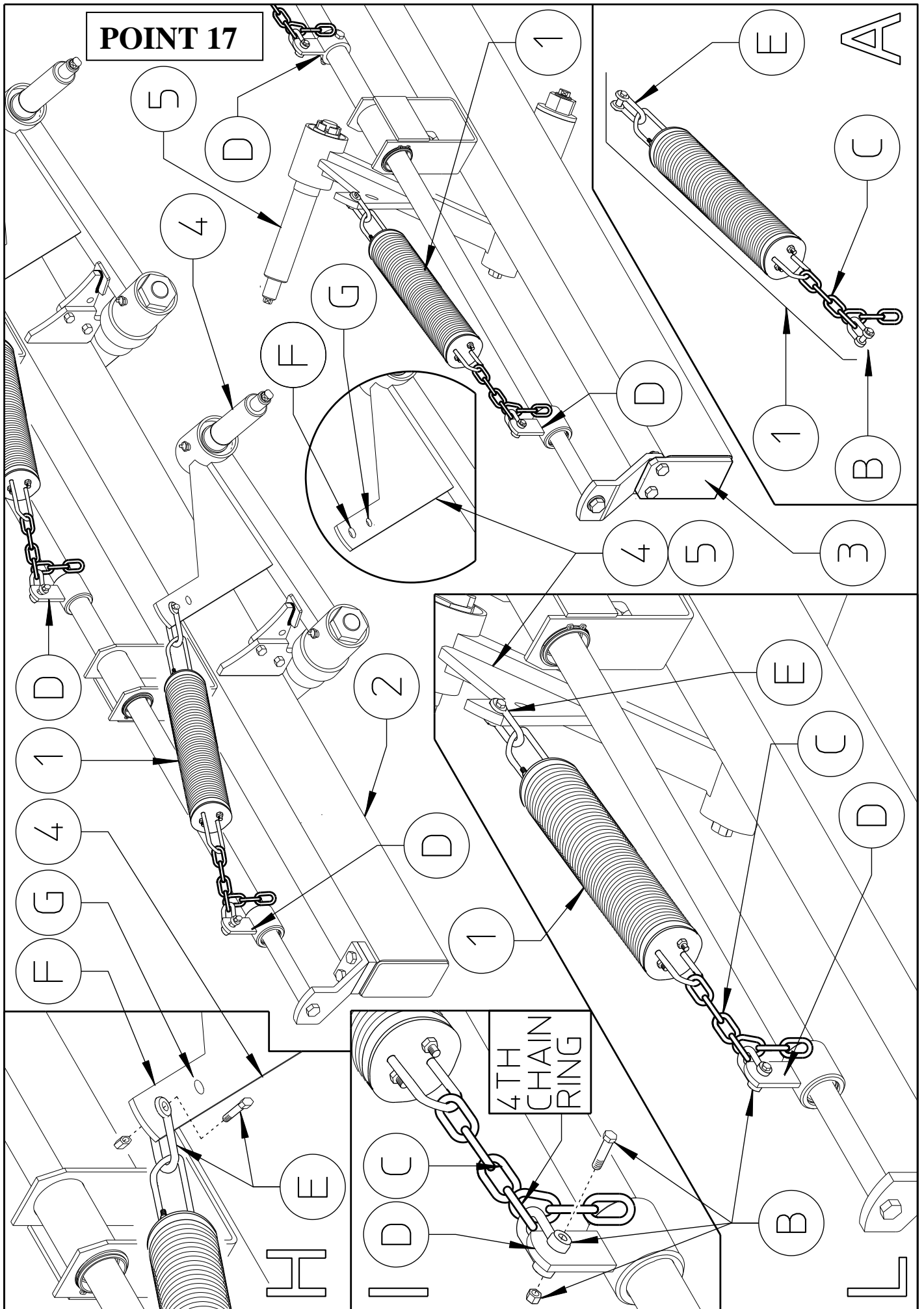

Point 17 (ATTENTION)

You have received seventeen spring pin assemblies 1 that have been pre-assembled by the manufacturer (see box “A”).

Every spring assembly consists of a set of parts such as the U-bolt “B” and chain “C”, which make it possible to hook onto brackets “D” on the rake wheel pipes on sections 2-3 (RH and LH), and U-bolt “E”, which makes it possible to hook onto holes “F” (the upper one) of the arm levers 4-5 (RH and LH). Besides these parts, described for assembly purposes, spring assembly 1 also consists of other parts, a complete list of which is found in the spare parts table 920.297.

Connect the side of spring assembly 1 that has the U-bolt “E” to hole “F” of the arm levers 4-5 (RH and LH) (see boxes “H”-“I”-“L”).

Connect the side of spring assembly 1 that has the chain “C” and the U-bolt “B” to brackets “D” on the rake wheel pipes on sections 2-3 (RH and LH) (see boxes “H”-“I”-“L”). Note: chain “C” has seven rings and U-bolt “B” was connected by the manufacturer to the 4th link (the middle link) as it is that most suitable on average for the working stage. For special user needs, the U-bolt “B” can be connected to other links, just as U-bolt “E”, which is normally connected to hole “F” on the arm levers 4-5 can be connected to hole “G” (the lower hole) on the arm levers 4-5. The effects of the possible adjustments of spring assembly 1 are described on pages 68-69-70-71-72-73; however, we mention briefly that when fewer links of chain “C” are used, the arms 4-5 (and respective rake wheels) are lowered less (rake wheels light on the ground), but the arms 4-5 (and respective rake wheels) are held more firmly when they are raised for transport, whereas when more links of chain “C” are used, the opposite effect is obtained.

In this step, you will use:

Item 1: n° 17 spring assemblies

POINT 18

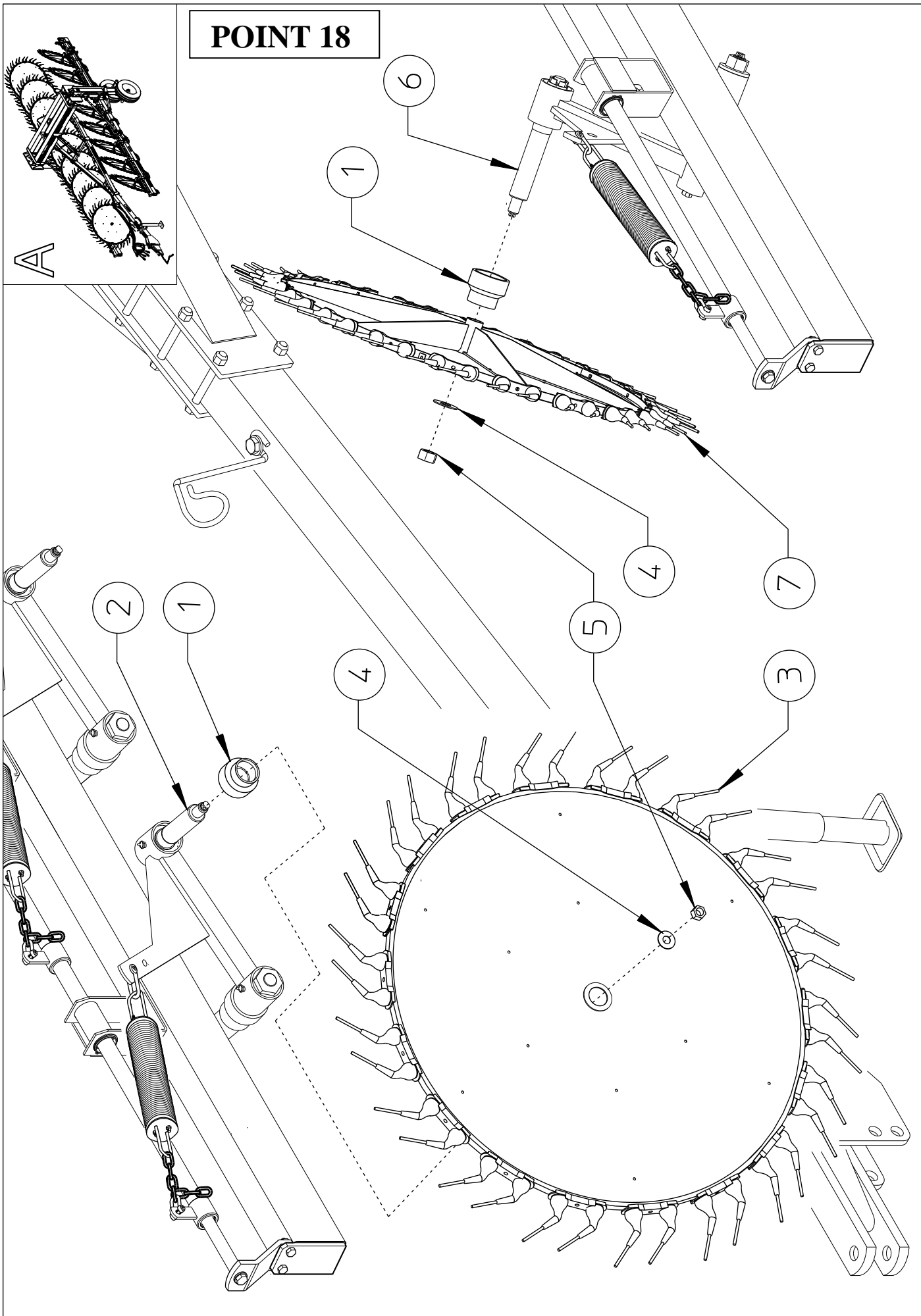

Point 18 (ATTENTION)

Attach protection 1 to the pin of RH arm 2. Connect the central washer of RH rake wheel 3 to the pin of RH arm 2 and fasten it with washer 4 and nut 5. There are nine RH rake wheels 3.

Attach protection 1 to the pin of LH arm 6. Connect the central washer of LH rake wheel 7 to the pin of LH arm 6 and fasten it with washer 4 and nut 5. There are eight LH rake wheels 7.

Now the machine is fully assembled and it appears as displayed in box “A”.

In this step, you will use:

Item 1: n° 34 protection

Item 4: n° 17 washer $\varnothing 23-50 \times 4$ ($\varnothing 0.91''-1.97'' \times 0.16''$)

Item 5: n° 17 nut M22 (0.87'')

The machine is ready to be lubricated and then used. See pages 62-63.

5) ADJUSTMENT, PREPARATION AND USE

a) attaching the machine to the tractor

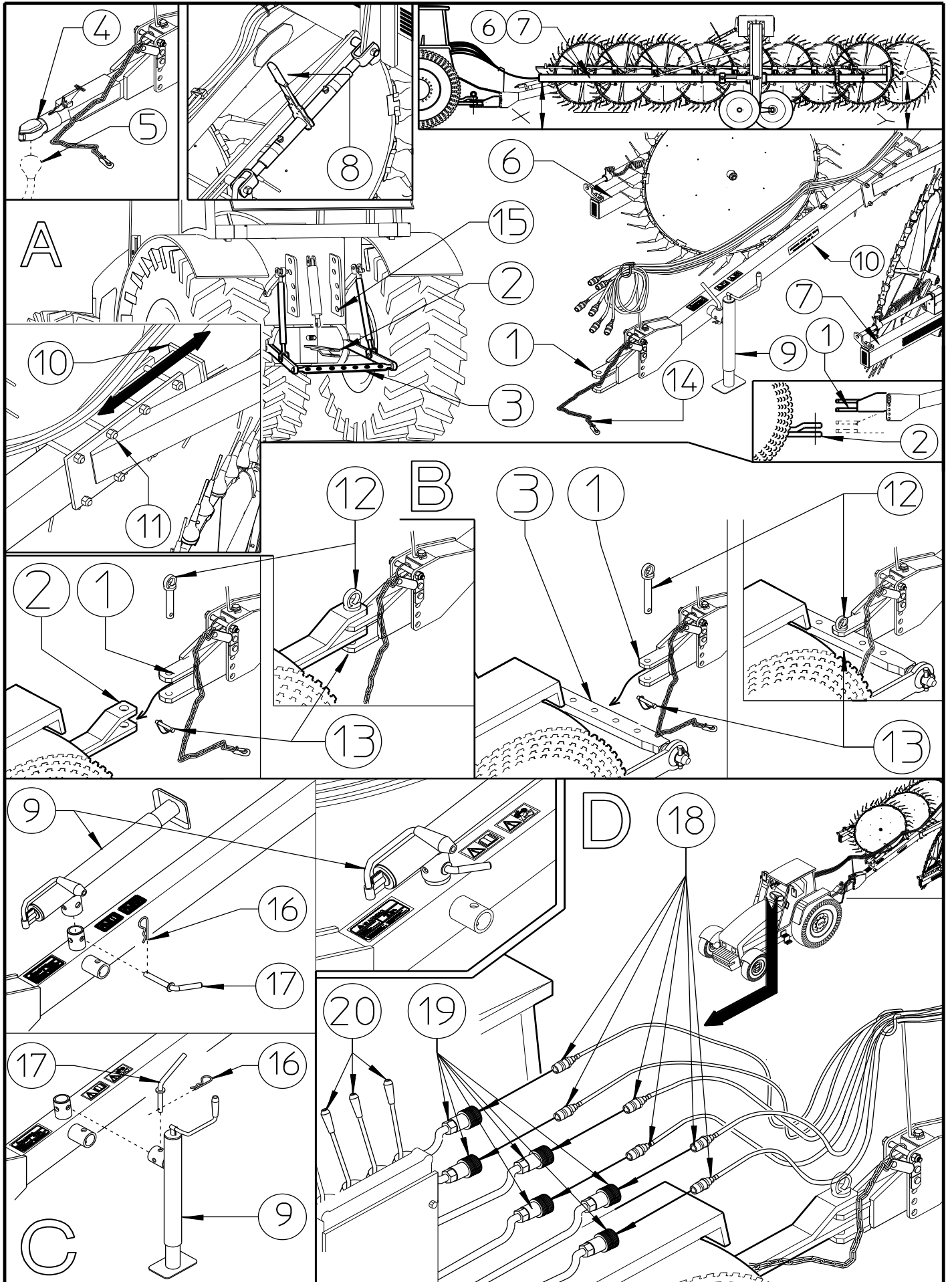

5) ADJUSTMENT, PREPARATION AND USE

a) attaching the machine to the tractor

The attachment of the machine to the tractor is simple but dangerous. Carry out the operation being extremely careful and strictly following these instructions. Make sure that there are no persons or objects within the operating range of the machine and tractor. Check that all the signs and symbols are on the machine and are legible. Check that the tractor is in good condition and is suitable for pulling and working with this machine. Always consult the tractor operator's manual.

The attachment to the tractor consists of joining the machine's hitch 1 to that of the tractor 2 or to the bar 3 attached to the tractor lifting arms (see box A).

An optional ball hitch 4 to be attached to the ball mount 5 is also available. In this case, carefully follow the instructions given in the manual for the hitch 4 and for the vehicle to which the ball mount 5 is attached (see box A). For everything else refer to the instructions given for hitches 1-2-3.

The attachment to the tractor is correct when sections 6-7 are approximately horizontal (parallel to the ground measurement $X = Y$ see box A).

If this is not the case, move lever 8 to level sections 6-7 (measurement $X = Y$). At this point, if there is a slight difference in height between the machine hitch 1 and the tractor hitch 2, adjust the parking stand 9 so that the hitches 1-2 are at the correct coupling position (see box A). If hitch 1 is much lower or higher than that of the tractor hitch 2, move the hitch 1 up or down using the series of holes on the drawbar (see box A and pages 20-21). Another possibility to optimize the coupling of the machine to the tractor (or another vehicle) is to move the drawbar 10 after loosening the nuts 11. If instead you attach the machine to the bar 3, the correct coupling height is achieved by raising or lowering the lifting arms. However, for all needs that may arise at the time of coupling hitches 1-3, the instruction given for hitches 1-2 will apply.

At this point, whether hitch 1 is attached to tractor hitch 2 or to the bar 3, you must fasten it using a pin 12 of adequate size and capacity for the weight of the machine and with a clips 13 (see Box B).

Now hook the safety chain 14 to a suitable connection 15 on the tractor (see Box A).

Once the machine is hitched to the tractor, the parking stand 9 must be raised from the parking position. To do this, remove the clip 16 and pin 17, remove the bushing in the parking stand and position vertically above the rudder. Stop in this position using the pin 17 and the clip 16 (see box C). Now connect the quick-release couplings 18 on the hydraulic circuit supply and return hoses to quick-release couplings 19 on the tractor. Note: The drawings of the hydraulic connections and levers are intended to give only a general idea of their shape and position.

From this moment on be very careful because any accidental movement of levers 20 will cause potential safety risks for anyone who is near the machine (see box D).

b) PREPARING THE MACHINE FOR FUNCTIONAL TESTS.

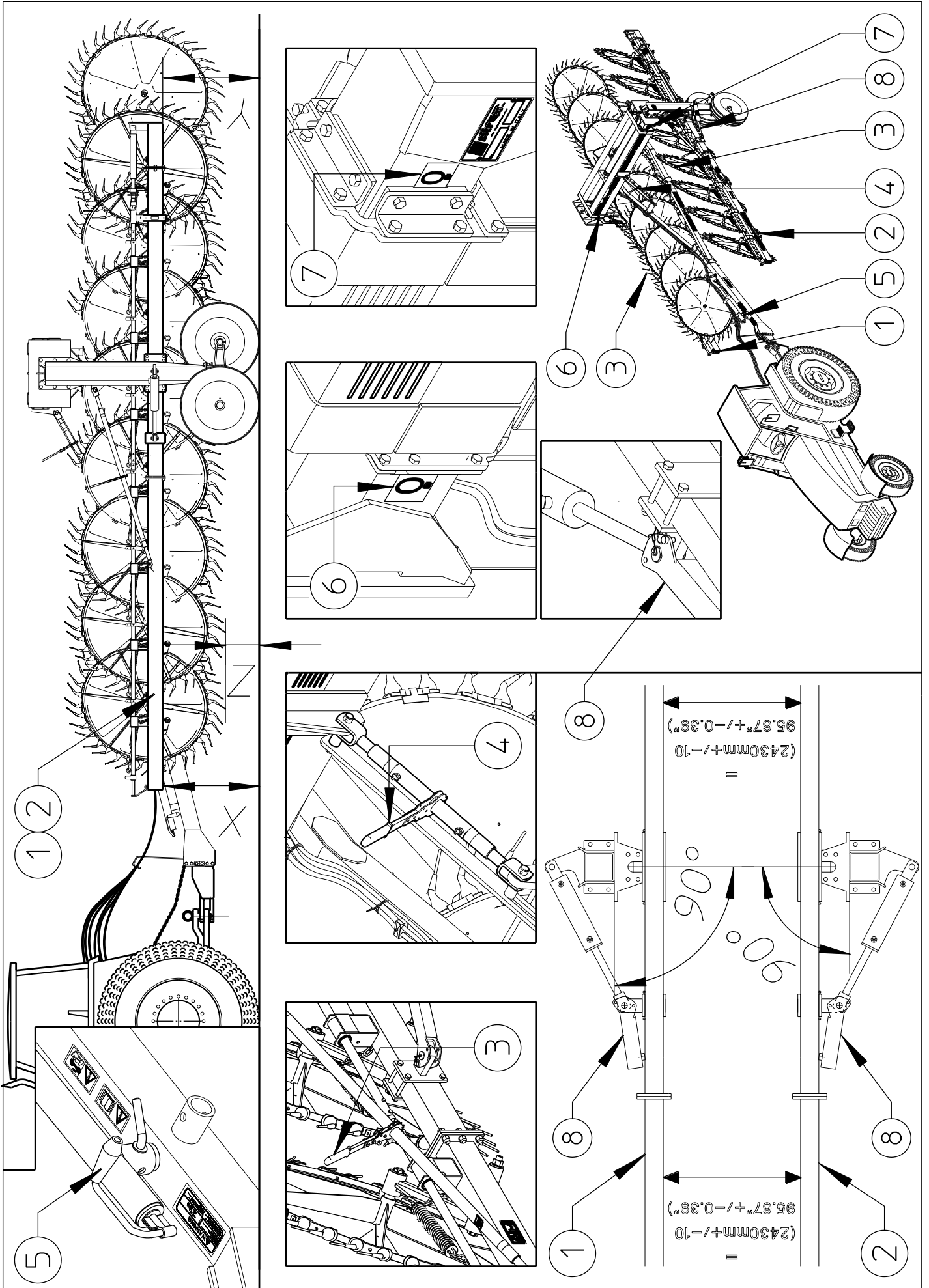

b) PREPARING THE MACHINE FOR FUNCTIONAL TESTS.

As mentioned earlier, the machine must be lubricated before proceeding with the functional tests (see pages 60-61). Check the parts lubricated by the manufacturer as well.

Before starting the machine for the functional tests, check to make sure that everything has been done correctly; therefore, before sending oil to the hydraulic cylinders, carry out the following checks:

- 1) sections 1-2 must be horizontal (parallel to the ground) and measurements X-Y (890mm- 35.04") should be approximately equal. It is correct, however, for measurement X to always be slightly greater than Y. To obtain this, move levers 3 appropriately. If for some reason there is a considerable difference between heights X and Y, then level the section with lever 4. Keep in mind that leveling with lever 4 has an effect on the machine-tractor hitches; (see pages 48-49)
- 2) the parking stand 5 must be in the work position;
- 3) the sliding crosspieces must be completely closed, i.e. they must be on the "0" of the graduated scales 6-7;
- 4) sections 1-2 must be parallel with each other at a distance of 2430mm – 95.67" from each other.
- 5) The cylinder latches 8 must be in working position (to put the latches 8 in working position, see pages 34-35).

b) FUNCTIONAL TESTS.

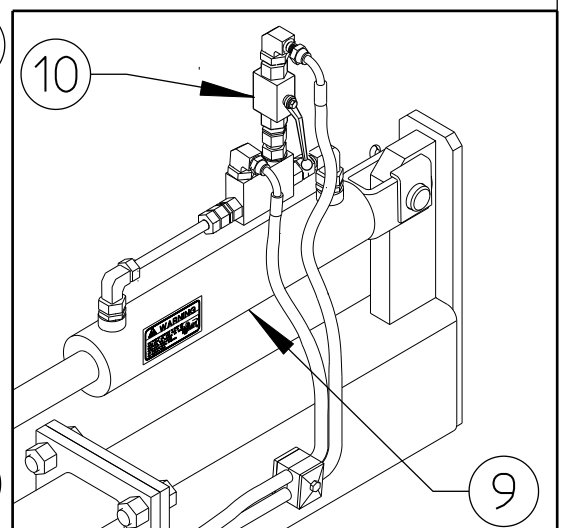
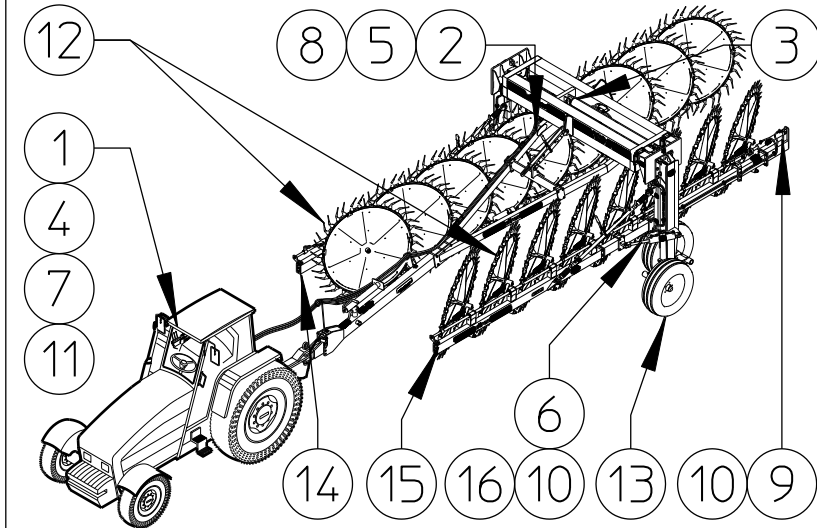
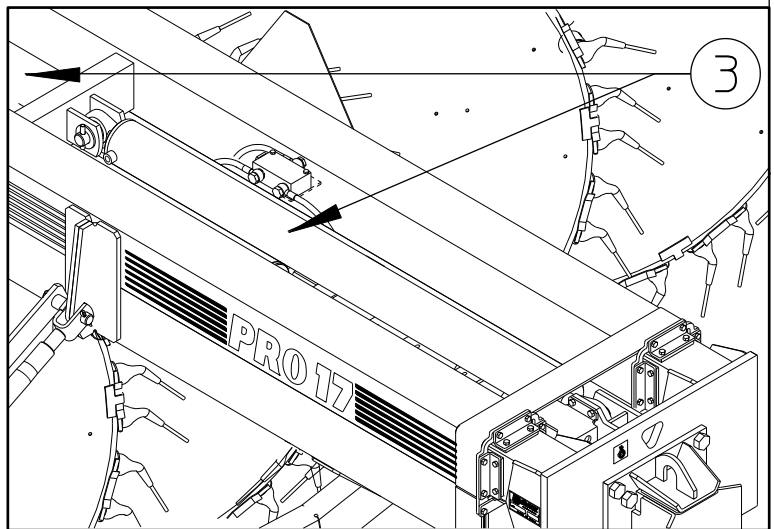
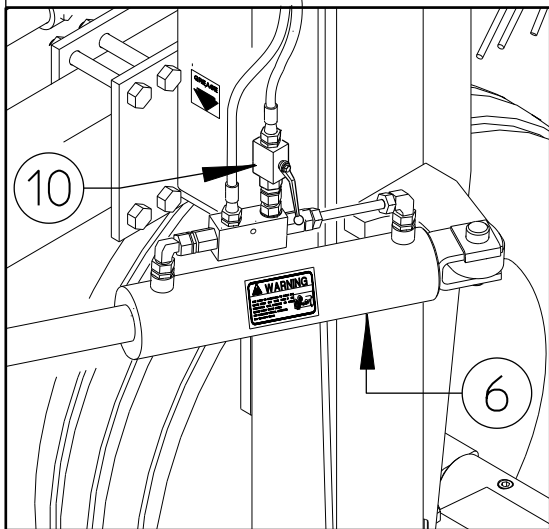
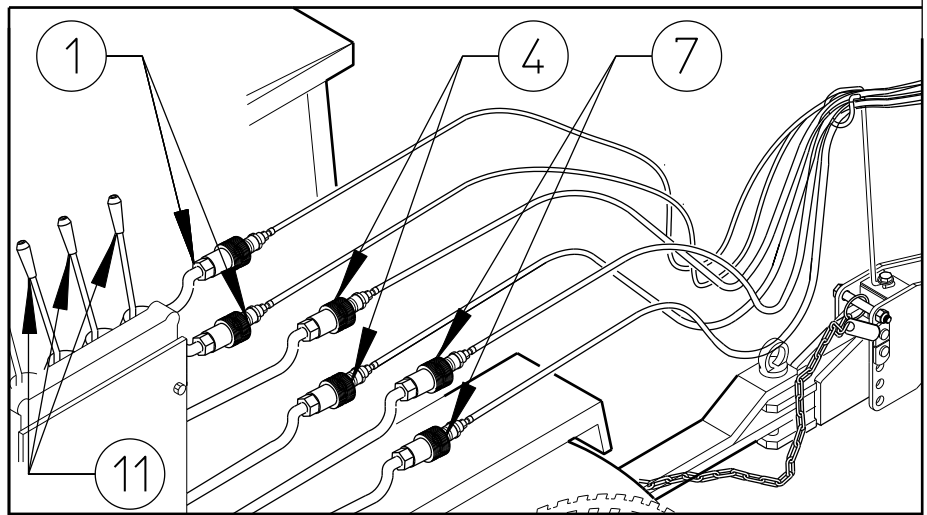
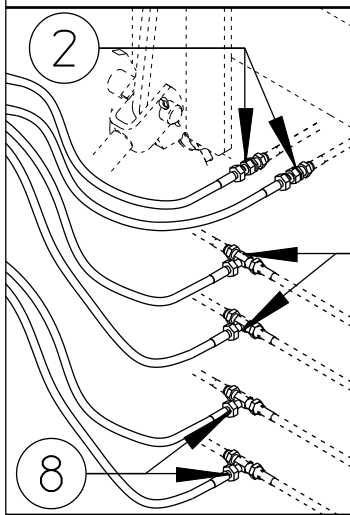
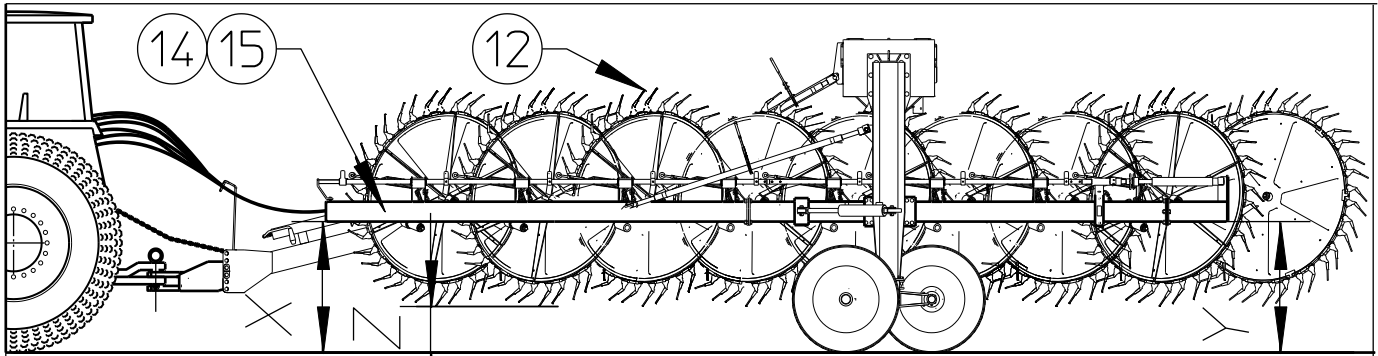

b) FUNCTIONAL TESTS.

NB: In this case, as the machine has just been assembled, the description given here is intended for the functional tests before transporting it and subsequently before working, but this procedure should be carried out every time you have to attach the machine to the tractor.

The two hoses 1 coming from point 2 control the cylinders for opening the frame 3, the two hoses 4 coming from point 5 control the sections cylinders 6 and the two hoses 7 coming from point 8 control the cylinders for raising the rake wheels 9.

Note: The drawings of the hydraulic connections and levers are intended to give only a general idea of their shape and position.

Check that the valves 10 on cylinders 9 are in the open position. At this point, send oil by moving lever 11, to which hoses 7 are connected, so that cylinders 9 start to extend and retract and thus to raise and lower the rake wheels 12. Do a few complete opening and closing cycles (3 or 4) so that cylinders 9 expel the air from the circuit. Closing valve 10 on one side and then on the other side, check that it is possible to work correctly with a section closed. Now, by moving lever 11, have cylinders 9 raise the rake wheels 12 to the right height Z (340mm - 13:39 ").

Before putting cylinders 3 into operation, make sure that the tractor has enough hydraulic oil to fill them, as they require about 16 liters/4 gallons. It is recommended that cylinders 3 be moved with the machine in motion (at slow speed), and if for some reason this is not possible, it is recommended that the test be done on a surface that allows the wheels 13 to slide sideways without significant friction. At this point send oil by moving lever 11, to which hoses 1 are connected, so that cylinders 3 start to extend and retract, and thus to open and close the sliding frames of the machine. Do a good number of complete opening and closing cycles (8 to 10) so that cylinders 3 expel the air from the circuit.

Note: Before moving angling cylinders of section 6 ensure that the cylinders 3 have fully expanded the frame to measure 4' (see pages 58-59 box C-D).

Check that the valves 10 on cylinders 6 are in the open position. At this point, send oil by moving lever 11, to which hoses 7 are connected, so that cylinders 6 start to extend and retract and consequently open sections 14-15 from 0 ° to 35 °, and vice versa. Do a few complete opening and closing cycles (6 or 7) so that cylinders 9 expel the air from the circuit. Closing valve 10 on one side and then on the other side, check that it is possible to work correctly with a section closed. Now, by appropriately acting on the hydraulic system, bring back sections 14-15 to 0 ° and restore the machine's frame to 0' opening (see pages 50-51).

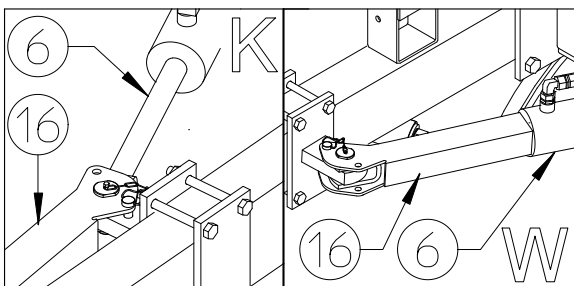

Bring back the latches 16 of the cylinders 6 from working position K to transport position W. To do this, see pages 34-35.

At this point the machine is ready for road transport and for work.

c) TRANSPORT BY ROAD

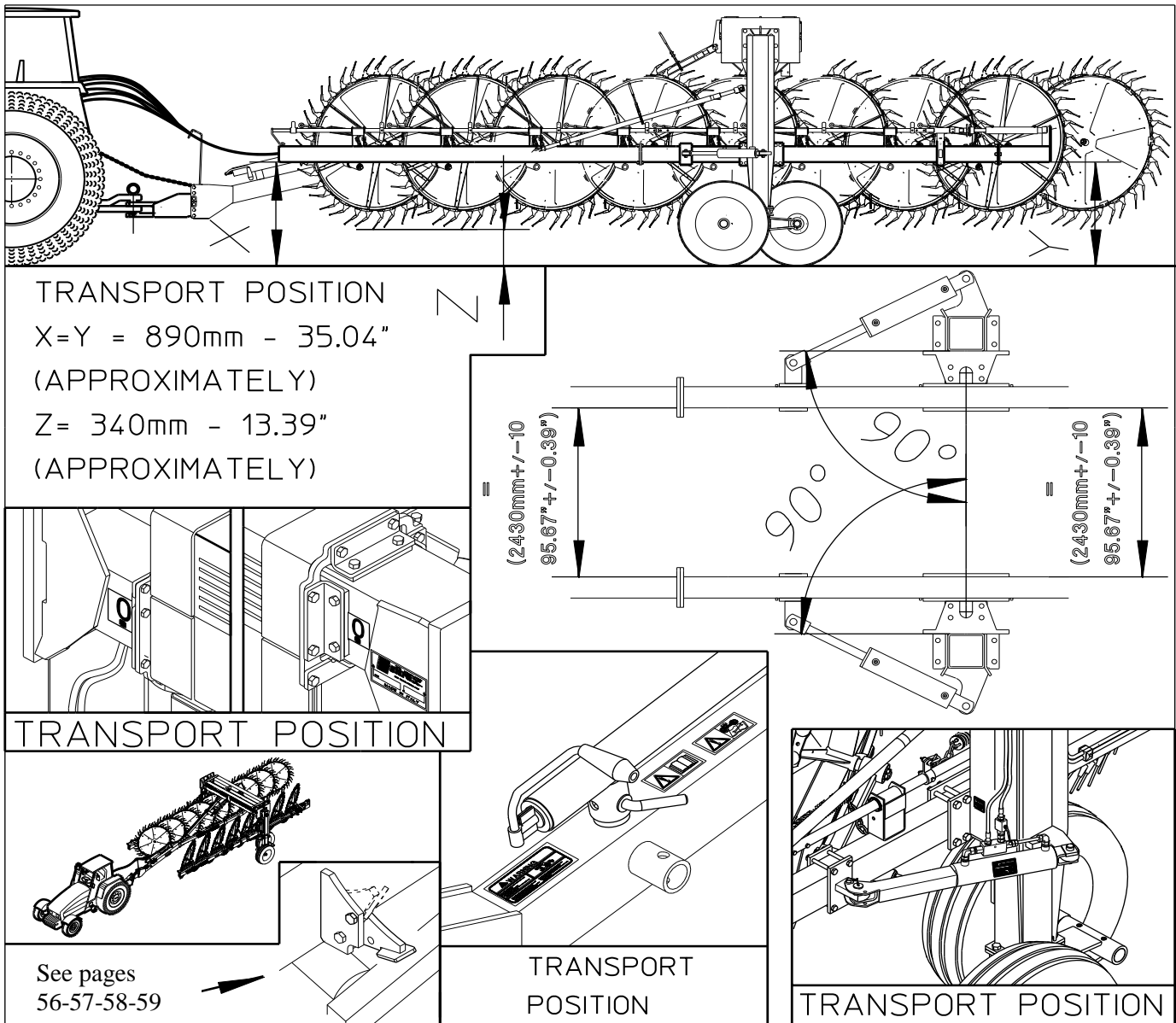

Whenever you transport the machine, check that the information shown on the drawing above is followed.

After the machine has been attached to the tractor as previously described and before transporting it to or from fields or any other workplace, the following instructions should be heeded:

Before setting off with the machine attached to the tractor, check the local road transport regulations. During transport keep the machine fully raised with the power takeoff disengaged and the lifting unit immobilised. Check that all guards, safety protection and locking split pins are in place, functioning and correctly fitted. Ensure that nobody leans against, or climbs on to, the machine during transport. Consult the tractor maintenance and use manual where necessary. Maintain constant control over the vehicle and ensure that you know how to stop the tractor quickly and switch off the engine. When on a public road, observe all highway code regulations. Drive near the edge of the road and try not to obstruct traffic. Do not park the tractor and/or the machine where it might obstruct, or be a danger to, any public right of way. Avoid going onto a public road if the tractor or machine is very dirty you could leave a trail of soil, grass and other matter which could dirty the road and obstruct normal traffic.

d) USE IN THE FIELD

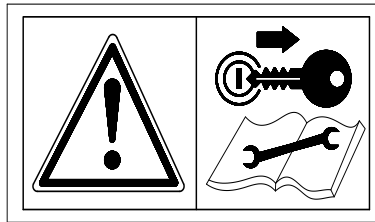
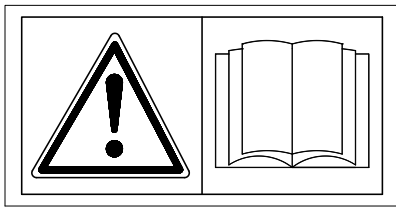

GENERAL INSTRUCTIONS FOR FIELD

Before starting work, familiarise yourself with the following general instructions:

Before using the machine ensure that all safety precautions are taken.

Check that all safety protection and guards are in place and working.

Inspect the work site in order to familiarise yourself with the terrain.

Do not start the tractor before being properly seated in the driving position.

Do not start the machine if it is damaged (or even if you only suspect it is damaged) and inform your nearest dealer of the problem and ask for assistance.

Do not allow yourself to become distracted when working give your full attention to the job in hand.

Maintain constant control over the tractor and ensure that you know how to stop quickly and switch off the engine.

Caution when working on inclines. It is better to work from the bottom to the top of an incline (or from the top to the bottom), rather than across an incline where there is a risk of overturning. Check and heed the instructions supplied by the tractor manufacturer, especially those concerning the maximum incline on which it is possible to work.

It is advisable to reduce speed when working and manoeuvring on inclines and only to change speed and direction gradually.

Do not make sudden stops or starts.

Do not work on wet or slippery grass or terrain, or anywhere where grip is poor. If this is unavoidable, work at a slow speed so as to ensure operator safety.

Always switch off the tractor engine, apply the parking brake and remove the ignition key whenever you have to attend to the machine to make adjustments or to remove grass and other objects which might be entangled in the machine.

Do not use the control levers as handholds since they can move and do not give a secure grip. Furthermore, any involuntary movement of a control lever can cause unintentional movement of the tractor or machine.

d) USE IN THE FIELD

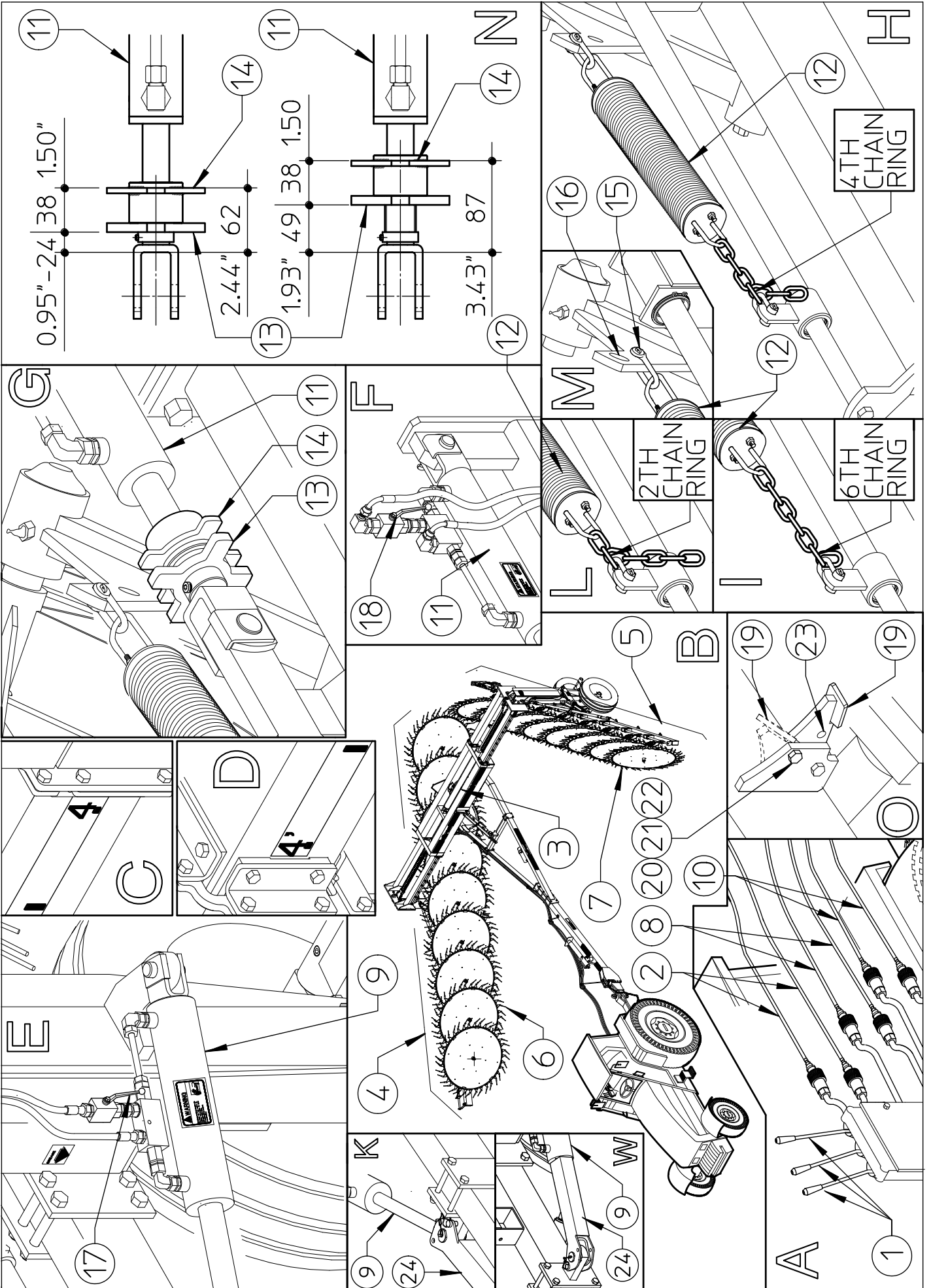

d) USE IN THE FIELD

The first thing to do when you are going to work is to open the machine frame. To do this, with the machine running, or at least on a surface that allows the transport wheels to slide sideways, move lever 1 connected to hoses 2 (see box A), which control the cylinders 3 (see box B) that open the sliding crosspieces to a max. width of 4' (see boxes C-D).

Note: if the sliding crosspieces are not opened to 4', the rake wheel sections 4-5 cannot be angled at the max. opening of 35° because they would interfere with each other. Now put the rake sections 4-5 in the working position (do this operation with the rake wheels 6-7 raised above the ground - see box B).

To do this you need to remove the latch 24 from transport position K and bring it into working position W (to do so see pages 34-35). Now using use lever 1, which is connected to hoses 8 that control cylinders 9, open sections 4-5 and put them in working position (see box A-B). Now using use lever 1, which is connected to hoses 10 that control cylinders 11, to lower the rake wheels 6-7 until they touch the ground (see boxes A-B-F-G). With the machine thus set up, start working, and after the first runs check that the work has been done correctly. If any adjustments are needed, do the following: If rake wheels 6-7 of rake sections 4-5 are too light on the ground (they do not collect all the hay), or are too heavy (they dig into the soil), some adjustments must be made to spring assemblies 12 (see boxes H-I-L-M). Before starting the adjustments to spring assemblies 12, place the machine on a flat, level surface and then check that the ring nuts 13-14 of cylinders 11 (see boxes G-N) are in contact with each other in the minimum degree of 38 mm – 1.50". If the rake wheels 6-7 leave hay uncollected, they must be adjusted to be heavier on the ground. To do this, the chain of spring assemblies 12 must be moved from the 4th link (see box H) as set by the manufacturer, or from whatever link was being used, to the 6th link (see box I). Connection to the 6th link as shown in box I is an example, and the operator may choose another more suitable link, bearing in mind that the longer the chain is in spring assembly 12, the heavier are the rake wheels 6-7. If rake wheels 4-5 dig into the soil, the contact with the ground must be lightened. To do this, the chain of spring assemblies 12 must be moved from the 4th link (see box H) as set by the manufacturer, or from whatever link was being used, to the 2nd link (see box L). Connection to the 2nd link as shown in box L is an example, and the operator may choose another more suitable link, bearing in mind that the shorter the chain is in spring assembly 12, the lighter are the rake wheels 6-7. At this point, if you want the rake wheels 6-7 to return to the same position every time they are lowered, adjust the movable ring nut 14 until it is in contact with the head of cylinder 11, then lock in place with ring nut 13 (see box N). Note: the maximum limit allowed by the ring nuts 13-14 is 87 mm-3.43". In addition, the ring nuts 13-14 of cylinders 11 allows the making of small adjustments to the pressure of rake wheels 6-7 without having to move the chains of spring assemblies 12 (a more complex operation), bearing in mind the concept that the more the distance of ring nuts 13-14 from the fork of cylinder 12 increases (do not go beyond the maximum limit of 87 mm-3.43"), the lighter are the rake wheels 6-7; vice versa, the more the distance of ring nuts 13-14 decreases, the heavier are the rake wheels 6-7. To avoid having the setting shift, once the adjustment is made, ring nuts 13-14 must be in forced contact in the minimum degree of 38 mm-1.50" (see box N). Another possible adjustment of the pressure against the ground of rake wheels 6-7 can be done by moving the attachment 15 of the spring assembly 12 from the upper hole 16 to the lower hole of the rake wheel arms (see box M). In this case, with all other adjustments remaining the same, one obtains both a greater weight on the ground of rake wheels 6-7 as well as greater stability during transport. Bear in mind that any adjustment you do to the rake wheels on the ground will also affect the transport conditions, according to the concept that the lighter rake wheels 6-7 are on the

d) USE IN THE FIELD

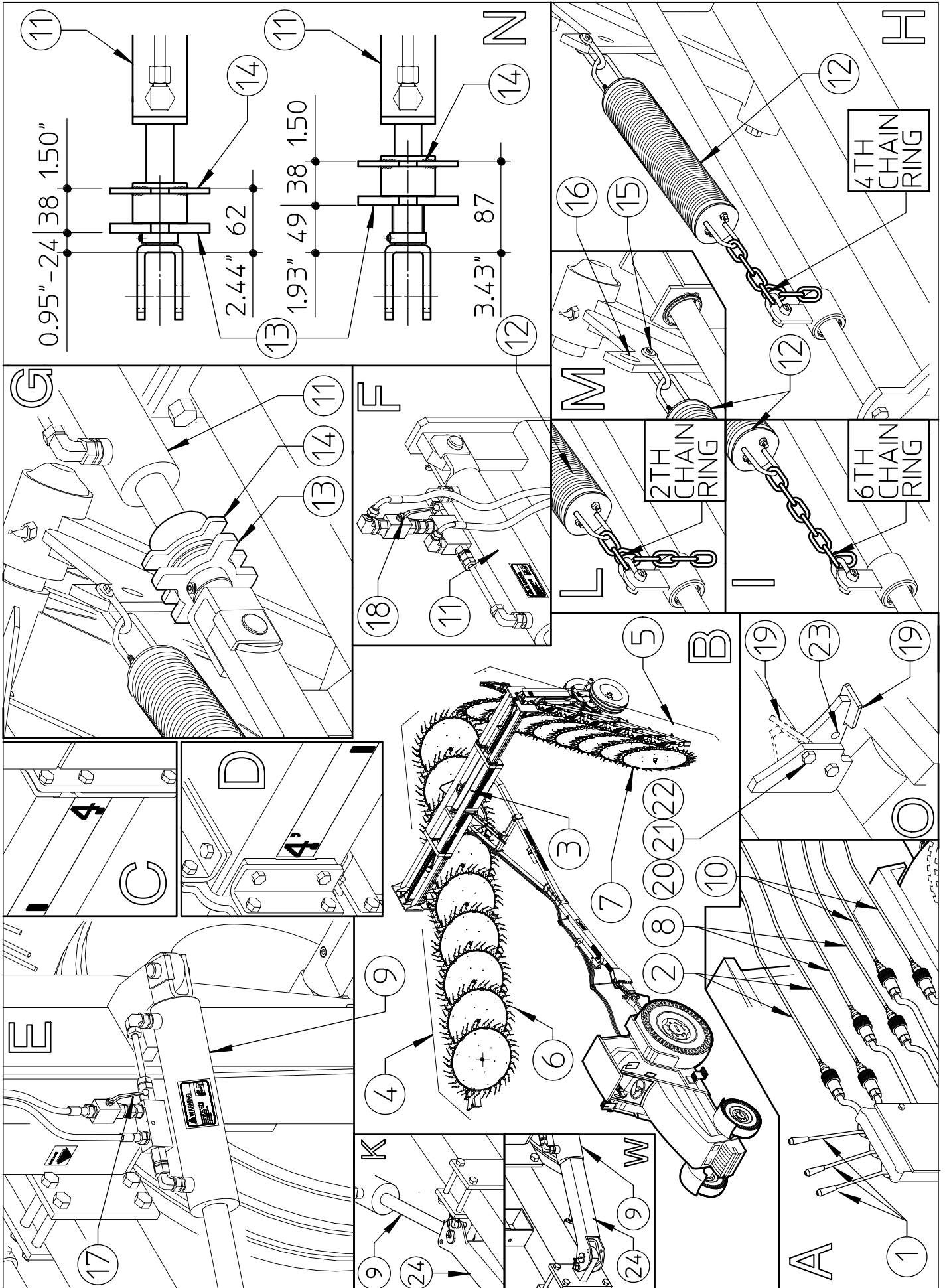

d) USE IN THE FIELD

ground, the more stable they will be during transport; vice versa, the heavier rake wheels 6-7 are on the ground, the less stable they will be during transport.

Therefore it is up to the operator to find the right compromise or to favor one of the two options, according to their needs.

Now, if you want to work with only one section (4 or 5) close them both, then , close the tap 17 of the cylinder 9 (see box E) on the side that you do not want to use. Then, if not already done, raise the fingerwheels 6-7, close the tap 18 of the cylinder 11(see box F) on the side that you do not want to use. To return to the previous condition, repeat the process in reverse.

The blocks 19 serve to stabilize the rake wheels 6-7 during transport, and the current position, also for the work stage, is the one shown in box O. When working on especially rough terrains, the rake wheels 6-7 move up and down considerably, such that the arms that hold them could knock against them violently and bend. To avoid this, remove the nut 20, washer 21 and bolt 22, then rotate the block 19 upwards and lock it in the new position by inserting the bolt 22 in hole 23. Tighten all with the washer 21 and the nut 20 (see box O).

Note: if you begin transport without putting the block 19 in the lower position the rake wheels 6-7 will be float slightly during transport, but if you travel at a moderate speed this will not create problems. For long distances over uneven ground, instead, the block 19 must be returned to the lowered position.

6) MAINTENANCE DIRECTIONS

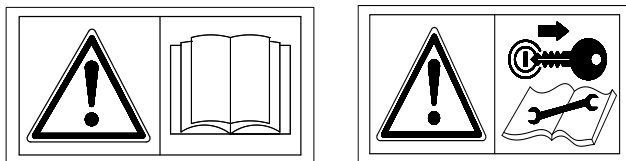

All cleaning, lubrication and maintenance operation must be carried out with the machine disconnected from the tractor.

In an emergency with the machine still connected to the tractor, switch off the engine, apply the parking brake, disengage the power takeoff and remove the ignition key from the instrument panel.

Regular, correct maintenance and proper operation are the basic prerequisites for the long-term efficiency and safe operation the machine.

Pay special attention to all instructions given on signs located on the machine.

All maintenance should be carried out in an area having the proper equipment readily available and in good condition.

This area must always be kept clean and dry and must have enough surrounding space to facilitate operations.

Any work must be carried out by trained personnel. Contact the dealer nearest to you.

Respect the warnings and procedures for maintenance and technical assistance given in this manual.

Do not use petrol, solvents or other flammable liquids as detergents.

Use commercial non-flammable and non-toxic solvents, authorised by competent bodies.

Do not use compressed air or water at high pressure to clean the machine. If this is unavoidable, then wear goggles with side protection and limit the pressure as much as possible. When the work is finished, and with the machine disconnected from the tractor, inspect and check the machine completely.

MAINTENANCE POINTS

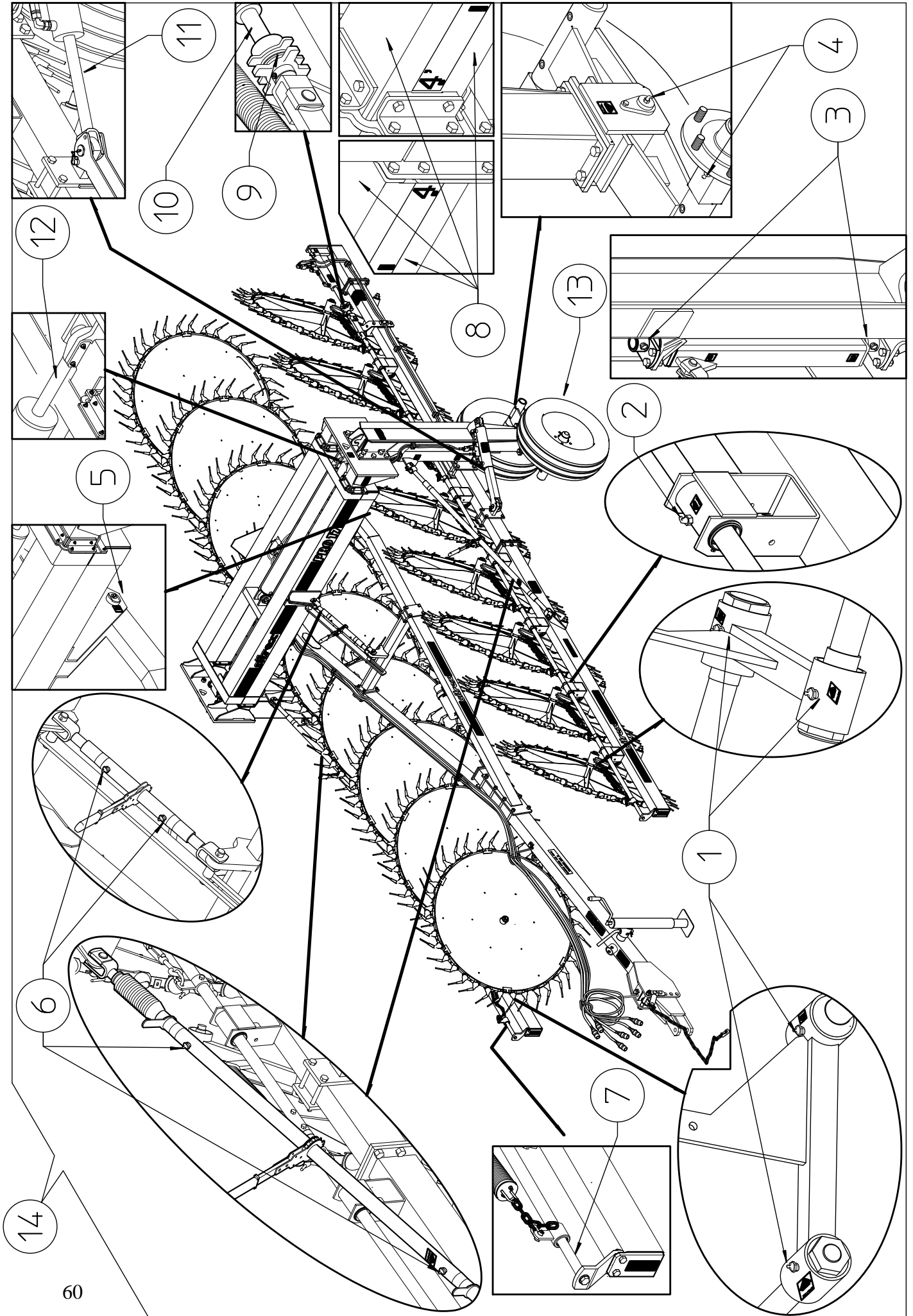

MAINTENANCE POINTS

ITEM	Q.ty	DESCRIPTION	OPERATION	Every hours	NOTES
1	34	RAKE WHEEL ARM	LUBRICATE	50	*
2	15	BUSHING	LUBRICATE	50	*
3	4	SECTION JOINT	LUBRICATE	50	*
4	6	TANDEM PIN AND HUB	LUBRICATE	50	*
5	2	DRAWBAR PIN	LUBRICATE	100	*
6	6	RATCHET LINK	LUBRICATE	100	*
7	2	SUPPORT PIN	CLEAN/ LUBRICATE	*	SEE NOTE A
8	2	SLIDING CROSSPIECE	CLEAN/ LUBRICATE	*	SEE NOTE B
9	2	ADJUSTMENT SCREWS	CLEAN/ LUBRICATE	*	SEE NOTE C
10	2	RAKE WHEEL LIFTING CYLINDER	CLEAN/ LUBRICATE	*	SEE NOTE D
11	2	SECTION OPENING CYLINDER	CLEAN/ LUBRICATE	*	SEE NOTE E
12	2	CROSSPIECE OPENING CYLINDER	CLEAN/ LUBRICATE	*	SEE NOTE F
13	4	WHEELS	CHECK PRESSURE	*	SEE NOTE G
14	-	General checking of bolts, security pins and split pins to be carried out initially after the first 8 hours of use. Subsequently every 50 hours and whenever the machine is laid up for extended periods.			
GREASE TYPE : NGLI 1 (NGLI 2)					

A = Every time the machine is used again after a rest period clean and brush with grease. Do this also at the end of the season when the machine is put away, and also when it is used again the next year, as the grease loses its effectiveness due to atmospheric agents.

B = Every time the machine is used again after a rest period clean and brush with grease the faces of the sliding tubular elements. Do this also at the end of the season when the machine is put away and also when it is used again the next year, as the grease loses its effectiveness due to atmospheric agents.

C = Each time an adjustment is made it is a good practice to clean and brush with grease to facilitate sliding. Do this also after a rest period, at the end of the season when the machine is put away and when it is used again the next year, as the grease loses its effectiveness due to atmospheric agents.

D = When the machine is not being used, either between one working period and another and even more so during winter, leave the cylinders closed so that the shafts are not exposed to atmospheric agents. Leaving the cylinders closed means that the rake wheels rest on the ground and thus they do not weigh on the springs and on the support structure. If for any reason the cylinders remain extended, clean and brush the shafts with grease. When they are to be used again, either after a brief period or even more so after winter, check to see if there are traces of rust on the shafts. If so eliminate the rust being careful not to scratch the surface.

E = When the machine is not being used, either between one working period and another and even more so during winter, if due to limited space the rake sections are closed and thus the cylinders are completely extended and the shafts are exposed to atmospheric agents, clean and brush them with grease. When they are to be used again, either after a brief period or even more so after winter, check to see if there are traces of rust on the shafts. If so eliminate the rust being careful not to scratch the surface.

F = When the machine is not being used, either between one working period and another and even more so during winter, if due to limited space the sliding crosspieces are closed, in this case the cylinders are completely closed and thus the shafts are not subject to the action of atmospheric agents. If for any reason the cylinders remain extended, clean and brush the shafts with grease. When they are to be used again, either after a brief period or even more so after winter, check to see if there are traces of rust on the shafts. If so eliminate the rust being careful not to scratch the surface.

G = Each time that the machine is used, either between one working period and another and even more so during winter, check the pressure of the tires, which should be 44 psi.

GENERAL INSTRUCTIONS FOR REPAIR WORK

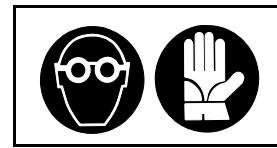
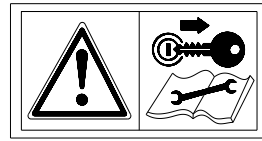
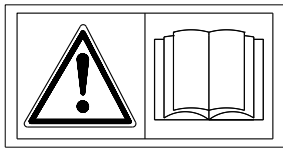

Any repair work must be carried out with the machine at rest and disconnected from the tractor.

Do not carry out welding without authorisation and instructions from the manufacturers.

Disconnect the machine from the tractor before any welding work in order not to damage the battery. Always use a protective mask, goggles and gloves when welding, sanding or grinding or when using a hammer or drill.

Always work on the machine out of doors. If you have to operate the machine when connected to the tractor in an enclosed area (for example when testing after repair and/or maintenance) ensure that there is sufficient ventilation so as to prevent noxious exhaust gases accumulating.

In order to acquire the necessary control and to operate in safety, practise various manoeuvres by simulating those required in the workplace with the help of an experienced person.

If you activate the machine while it is raised from the ground, make sure there is nobody standing nearby or in a dangerous position.

LAYNING UP FOR EXTENDED PERIODS

At the end of the season, or when an extended period of inactivity is envisaged, it is advisable to:

Clean the machine following instructions and allow it to dry.

Check it carefully and replace any damaged or worn parts.

Thoroughly tighten all screws and bolts.

Grease the machine thoroughly and then cover it completely and lay it up in a dry place.

It is to the user's advantage to carry out these operations carefully. In this way, he will have a machine in perfect condition when work is restarted.

On recommencing work, repeat all the proper checks so as to be certain of working in conditions of maximum safety.

NOISE AND VIBRATION

Noise affecting the tractor driver (from the machine only) is less than 80dB.

Vibration from the machine affecting the upper body and limbs of the driver is insignificant and is lower than the values given in Point 3.6.3 of Enclosure 1 of the Machine Directives (89/392/EEC, 91/386/EEC)

THE FOLLOWING SHOULD BE NOTED IF THE MACHINE IS SCRAPPED

The machine consists mainly of ferrous material, which must be disposed of according to the regulations in force in the country concerned.

There is also a small amount of plastic, which must be disposed of according to the regulations in force in the country concerned.

There is very small amount of residual grease, which must be disposed of according to the regulations in force in the country concerned.

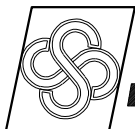

AGRICULTURAL MACHINERY
sitrex® SpA

Zona Industriale-Viale Grecia, 8
06018 TRESTINA-(Perugia)-ITALY
Tel. +39.075.8540021-Telefax +39.075.8540523
e-mail: sitrex@sitrex.it www.sitrex.com

